

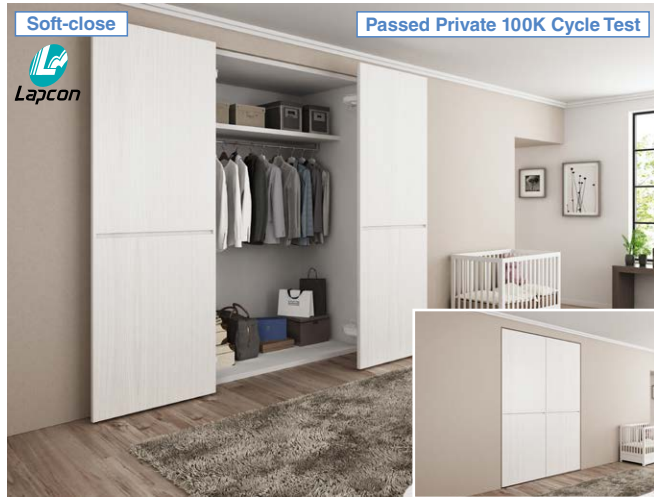

LAMP MONOFLAT LIN-X HINGE LIN-X800



MonoFlat LIN-X hinge

	LIN-X800	LIN-X800H
Door Width	750 - 850 mm	
Door Height	Max. 2400 mm	Max. 2980 mm
Door Thickness	24 - 40 mm	
Door Weight	Max. 40 kg per door	
Usage	1 per door (Overlay)	

SELECTION GUIDE

LATERAL OPENING DOOR

HES CONCEALED HINGES

SWING DOOR

DOOR DAMPERS

DOOR STOPPERS

STACKABLE PARTITION DOOR

SLIDING DOOR



- **Innovative movement keeps doors discretely out of the way.**
Door closes flush with surrounding walls for a sleek and clean design.
No need to do special processing on any wall for grooves or rails. Can be used on aluminium frames (if the frame has a thickness over 120 mm).
- **Whether open or closed, door stays out of the way**
Compared to regular swing doors, has a small radius allowing the space in front of the door to be used effectively.
- **Full access to cabinet interior.**
Door will not get in the way when fully opened.
- **Built-in soft close mechanism**
When the door closes, the internal damper will cause the door to close softly, preventing slamming.
- **4 Way adjustment post installation**
Can be adjusted vertically, horizontally, depth or parallel.
- **Wide amount of applicable cabinets**
Can be used on dual opening, single opening cabinets. Can also be used on L shaped corner spaces.

INSTRUCTION SCREW

Parts Included

- OTruss head tapping screw 6*25
- Truss head screw M5 x 10
- M5 Square Nut
- One end mouth wrench

Colour Variation



Black



White

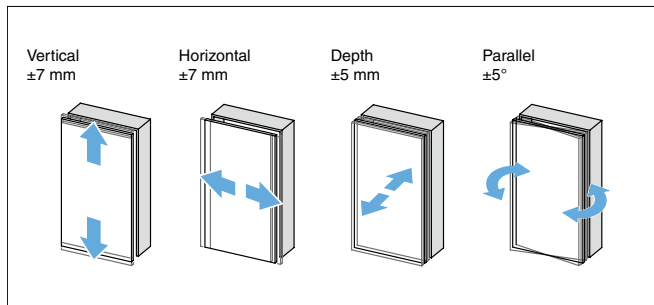

*Vertical, Horizontal, Depth and Parallel adjustment possible post-installation.

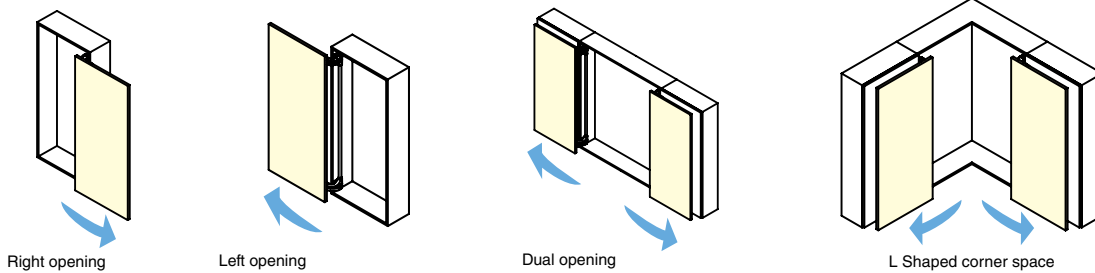

How to Order
LIN-X800

• Required Parts.....

Part Set (per door)

E
ARCHITECTURAL DOOR
HARDWARE

Part Set (per door)

This set must be ordered. Select a suitable set according to the door height.

Item Code	Item Name	Door Height	Colour	Set Content (for LIN-X800)			
				1 Hinge + 2 3 Washer Cover + 4 Rod Cover		5 Connecting Rod	
				Item Code	Item Name	Item Code	Item Name
250-043-897	LIN-X800-BL-S	2400 mm	Black	250-043-834	LIN-X800-BL	250-043-842	LIN-X80-L2100-BL
250-043-898	LIN-X800-WT-S	or Less	White	250-043-835	LIN-X800-WT	250-043-843	LIN-X80-L2100-SL
250-043-899	LIN-X800H-BL-S	2980 mm	Black	250-043-834	LIN-X800-BL	250-043-844	LIN-X80-L2500-BL
250-043-900	LIN-X800H-WT-S	or Less	White	250-043-835	LIN-X800-WT	250-043-845	LIN-X80-L2500-SL

SELECTION GUIDE

LATERAL OPENING DOOR

HES CONCEALED HINGES

SWING DOOR

DOOR DAMPERS

DOOR STOPPERS

STACKABLE PARTITION DOOR

SLIDING DOOR

Part Set Contents

No. Quantity	Parts in Set	Dimensions	Specifications
A - B 1 each	Hinge A		*Material: Steel (SPCC)/ Polyacetal (POM) *Finish: Nickel Plating Baked enamel finish
	Hinge B		

No. Quantity	Parts in Set	Dimensions	Specifications
2	Washer cover (hanging side)		*Material: ABS resin
3	Washer cover (leading edge)		*Material: ABS resin
4	Rod cover		*Material: Polyacetal (POM)

No. Quantity	Parts in Set	Dimensions	Specifications
5 Either part	Connecting rod		*Material: Aluminium alloy *Finish: Anodised: Black/silver
			*Material: Aluminium alloy *Finish: Anodised: Black/silver

Detailed Drawing

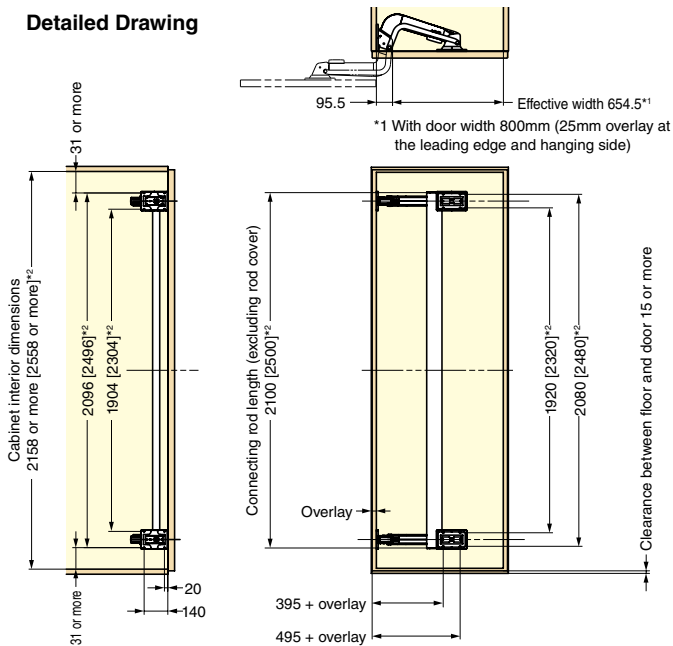

Range of Motion

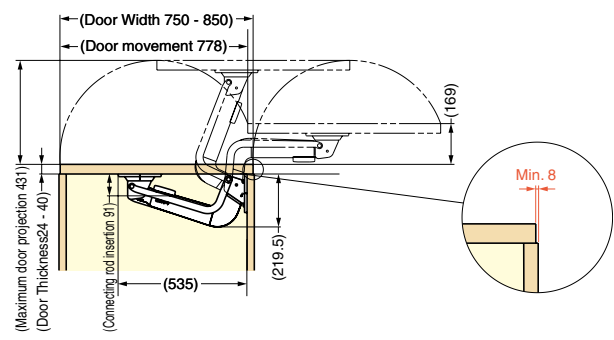

*2 The dimensions in [] indicate LIN-X800H specifications.

*2 For cabinet interior dimensions smaller than the minimum value, reduce the other dimensions marked with *2 by an equivalent amount. The connecting rod must be cut by the customer.