

# PB15

## **Sistema scorrevole per ante rientranti**

Sliding system for pocket doors

Système coulissant pour portes escamotables

Drehschiebetürbeschlag für Möbelschranke

Sistema corredero para puertas escamoteables

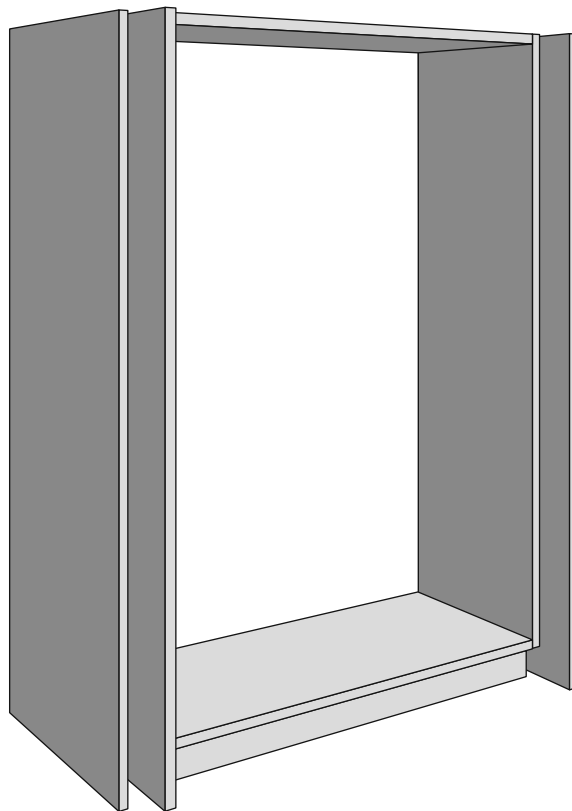
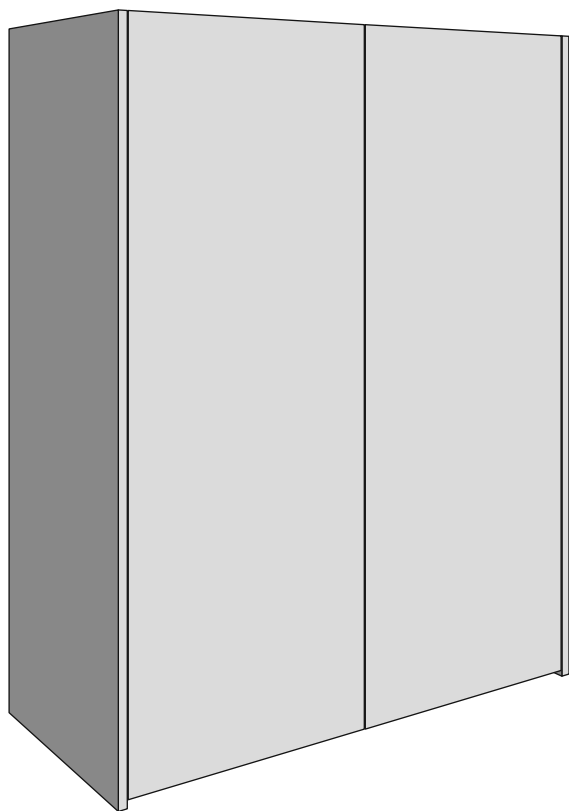

## **MANUALE TECNICO**

TECHNICAL HANDBOOK

MANUEL TECHNIQUE

TECHNISCHES HANDBUCH

MANUAL TÉCNICO





**QUESTO MANUALE TECNICO SI RIFERISCE ALLA REALIZZAZIONE DI ANTE SCORREVOLI RIENTRANTI PB15 I CUI MECCANISMI RIPORTANO I SEGUENTI CODICI: PB15KT70000021, PB15KT70000022, PB15KT70000023, PB15KT70000024, PB15KT70000025, PB15KT70000026, PB15KT70000027, PB15KT70000028, PB15KT70000029, PB15KT70000030, PB15KT70000031, PB15KT70000032.**

THIS TECHNICAL HANDBOOK REFERS TO THE MANUFACTURE OF PB15 RETRACTING SLIDING DOORS WHOSE MECHANISMS BEAR THE FOLLOWING CODES: PB15KT70000021, PB15KT70000022, PB15KT70000023, PB15KT70000024, PB15KT70000025, PB15KT70000026, PB15KT70000027, PB15KT70000028, PB15KT70000029, PB15KT70000030, PB15KT70000031, PB15KT70000032.

### Italiano

Tutte le misure espresse in questo opuscolo sono in millimetri.

### ATTENZIONE

Non utilizzare spray ed oli anti frizione o sblocca filetti sui cuscinetti o sulle ruote con O-ring dei pattini scorrevoli. Questo provoca lo scioglimento dei grassi dei cuscinetti rendendoli rumorosi oppure la rottura dell'O-ring.

Le illustrazioni e le descrizioni di questo opuscolo si intendono fornite a titolo indicativo. L'azienda si riserva pertanto di apportare, in qualsiasi momento e senza preavviso, quelle modifiche che ritenesse utili per qualsiasi esigenza di carattere costruttivo e commerciale.

### Deutsch

Alle Maße in diesem Katalog sind in Millimetern.

### ACHTUNG

Kein Spray, Schmiermittel oder Lösenmittel auf die Kugellager und Rollen mit O-Ring der Laufwagen verwenden. Das kann die Kugellager und die Rollen geräuschvoller machen und kann den O-Ring Abriss verursachen.

Die Bilder und Beschreibungen dieses Prospektes sind nur zur Information gegeben. Die Firma kann, in jedem Moment, Änderungen und Verbesserungen ohne Vorankündigung vornehmen.

### English

All dimensions in this leaflet are stated in millimeters.

### WARNING

Do not use any anti-friction oil or grease or thread-release spray on ball bearing or on wheels with O-ring, it can cause the melting of the inside ball bearing grease, making them noisy or causing the break of the O-ring of the wheels.

The pictures and descriptions this leaflet contains are supplied for information purposes. The company reserves the right to introduce those modifications it deems opportune for any construction or commercial need at any time and without advance notice.

### Español

Todas las dimensiones en este folleto se expresan en milímetros.

### ADVERTENCIA

No utilices spray y aceites anti-fricción sobre los cojinetes de bolas y sobre las ruedas con O-ring de los patines. Esto puede provocar mayor rumorosidad de los cojines o la rotura de los O-ring.

Las imágenes y las descripciones de este folleto solo se fechan a título informativo. La empresa puede aportar, en cualquier momento y sin preaviso, las modificaciones que cree necesarias por exigencias técnicas y comerciales.

### Français

Toutes les mesures indiquées dans cette brochure sont en millimètres.

### AVERTISSEMENT

Ne pas utiliser de spray ni d'huile anti frottement ou pour débloquer les filets sur les coussinets ou sur les roulettes avec bague torique des patins coulissants. Ce qui ferait fondre la graisse des roulements en les rendant bruyants ou provoquerait la rupture de la bague torique.

Les images et les descriptions de cette notice ne sont fournies qu'à titre indicatif. Le fabricant se réserve donc le droit d'apporter toutes les modifications qu'il jugera utiles à des fins techniques et commerciales à n'importe quel moment et sans aucun préavis.









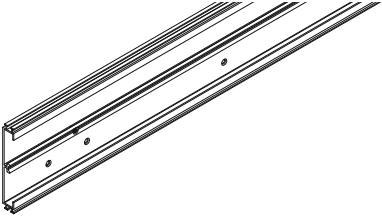

## Panoramica dei componenti.

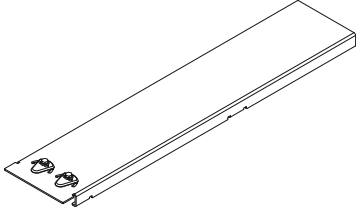
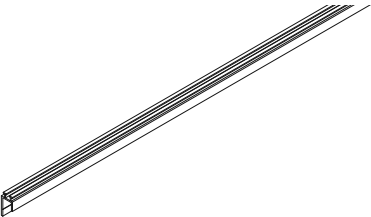
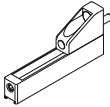
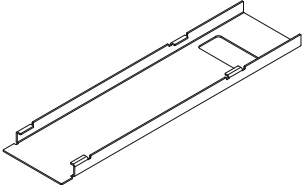
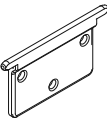
Parts list overview.

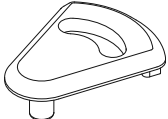
Aperçu général des composants.

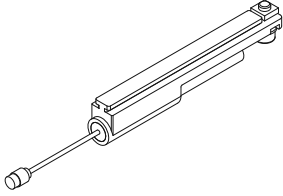
Übersicht der Bestandteile.

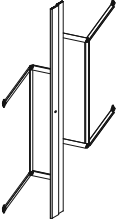
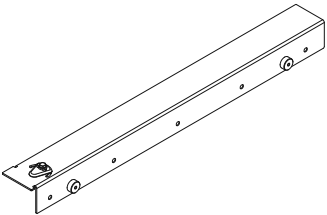
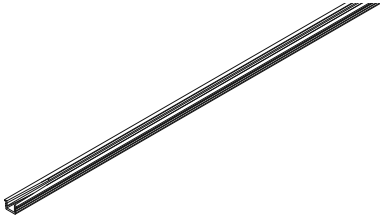
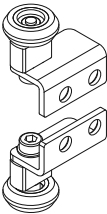
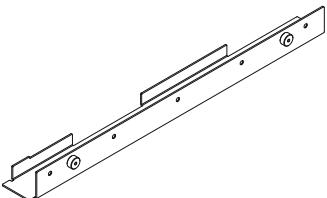
Esquema de componentes.

<p><b>1</b> SP7BN0020006</p> 	<p><b>7</b> VL60100611</p> 	<p><b>13</b> GGAC1VN60005</p> 
<p><b>2</b> SP7BN0020005</p> 	<p><b>8</b> GGAC81200002</p> 	<p><b>14</b> LT123VN6200008</p> 
<p><b>3</b> TE865160000305</p> 	<p><b>9</b> TR8780822022</p> 	<p><b>15</b> TE868160000304</p> 
<p><b>4</b> TE865160000303</p> 	<p><b>10</b> GGAC81200001</p> 	<p><b>16</b> VM85100506</p> 
<p><b>5</b> *** (page 4)</p> 	<p><b>11</b> GGAC1VN60017 (R) / 19 (L)</p> 	<p><b>17</b> SP7BN9020001</p> 
<p><b>6</b> CN01000482</p> 	<p><b>12</b> GGAC1VN60018 (R) / 20 (L)</p> 	<p><b>18</b> TE884200000309</p> 

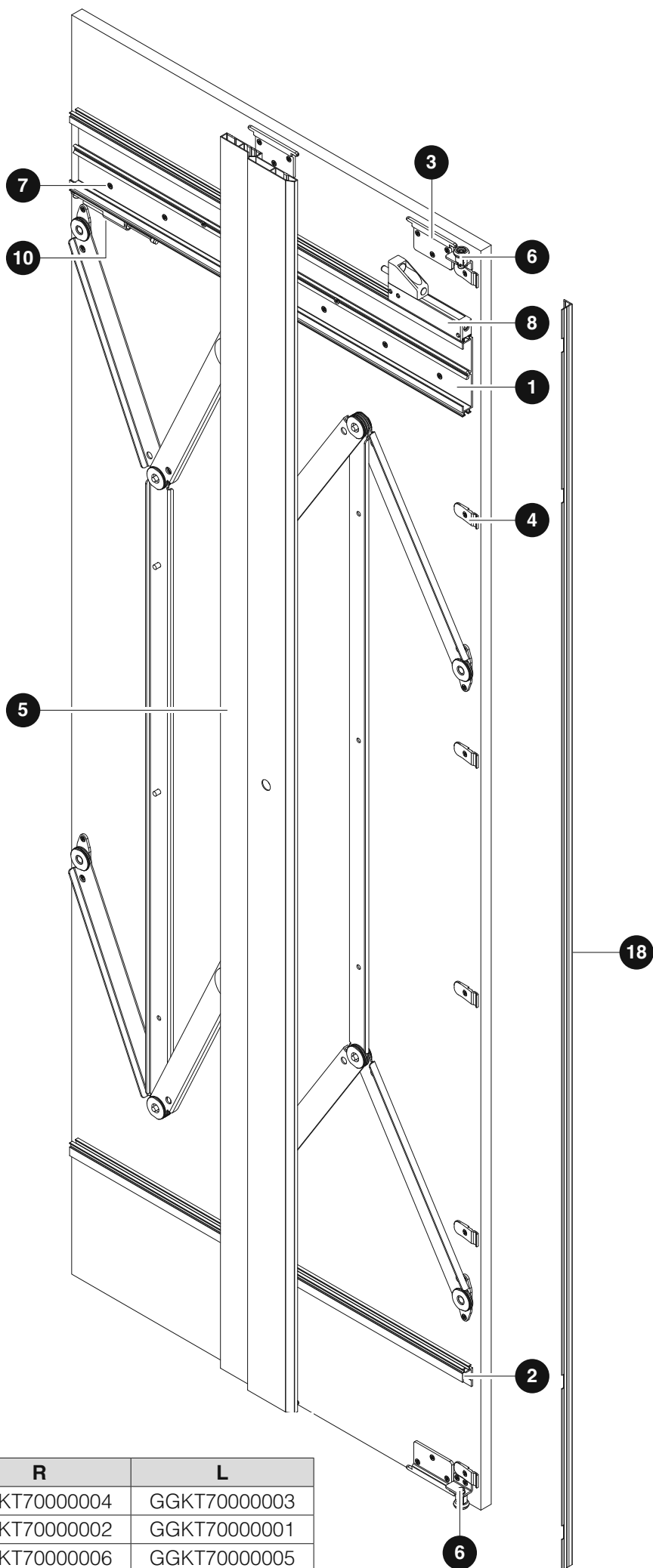

**5** \*\*\*

H	R	L
<b>1600÷2000</b>	GGKT70000004	GGKT70000003
<b>2000÷2400</b>	GGKT70000002	GGKT70000001
<b>2400÷2800</b>	GGKT70000006	GGKT70000005

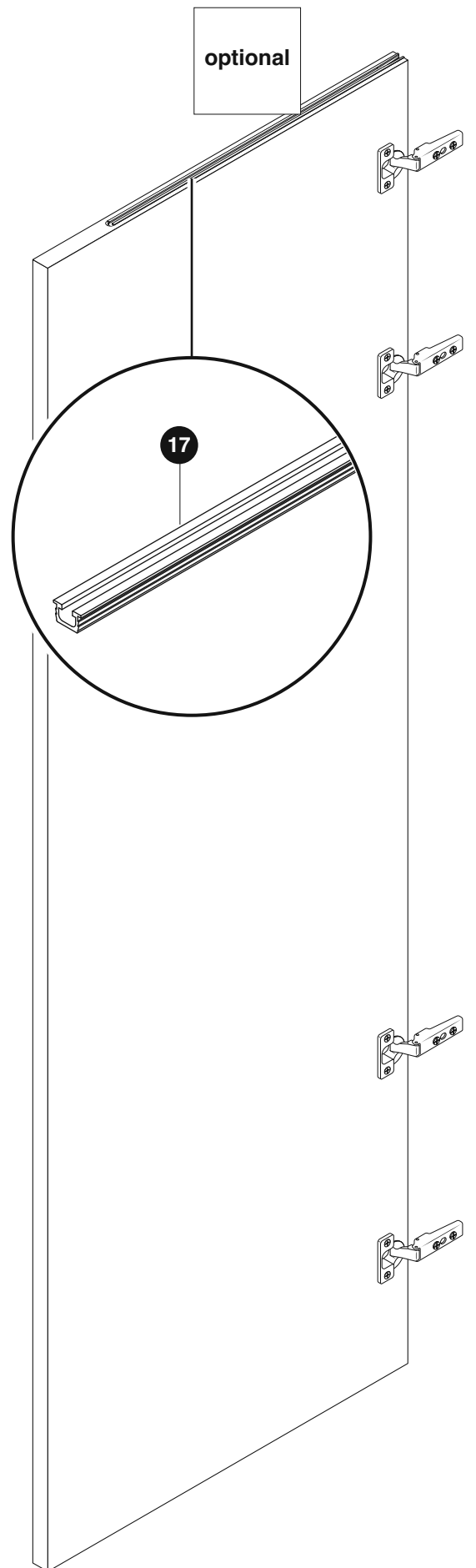
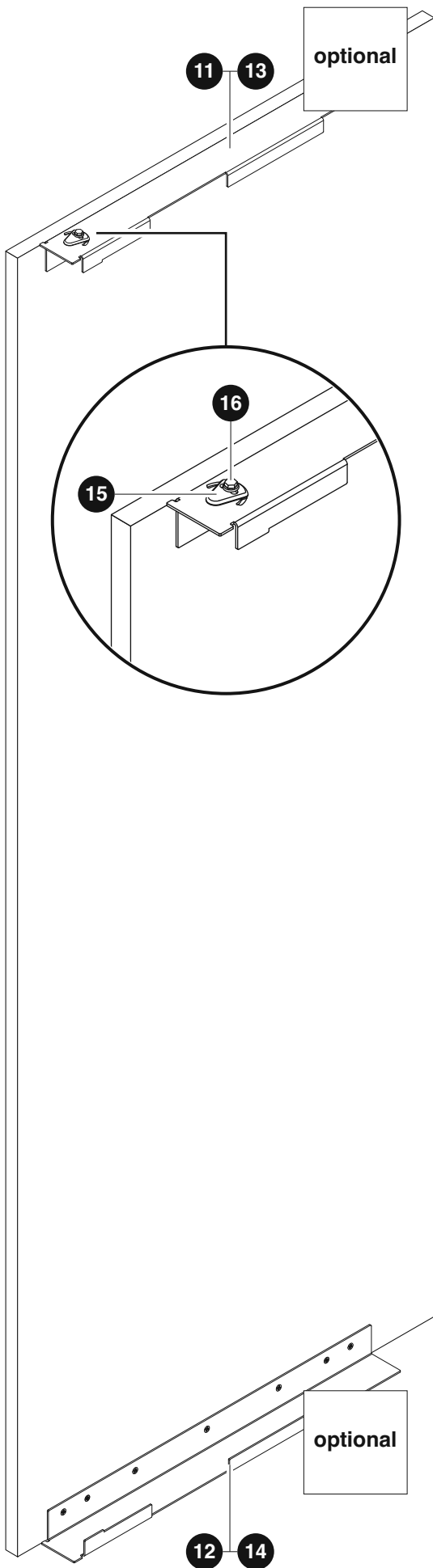

## Informazioni sul prodotto.

Product information.

Informations sur le produit.

Produktinformation.

Información sobre el producto.

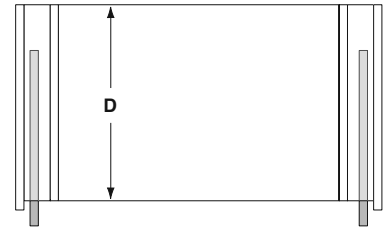
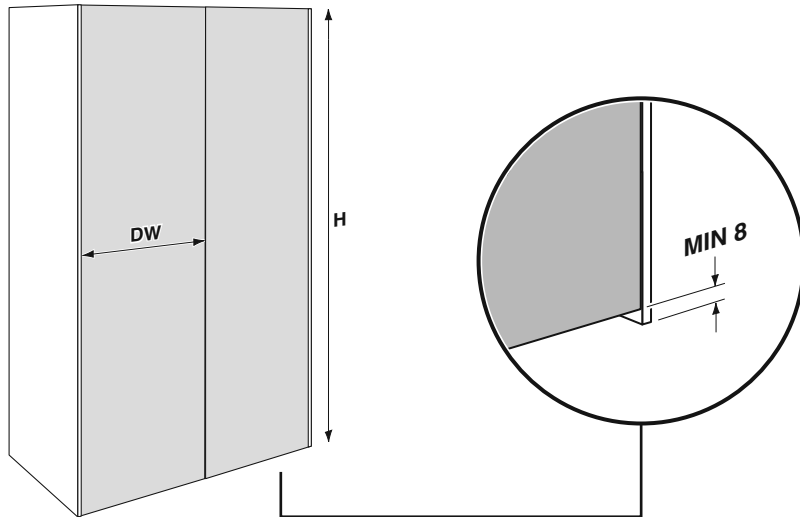

H	1600÷2000	R - L
	2000÷2400	R - L
	2400÷2800	R - L
DW	400÷700	
D	550÷1000	

## SPECIFICHE TECNICHE DELL'ANTA

DOOR TECHNICAL DATA.

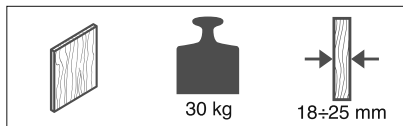

### Si raccomanda di usare una guarnitura raddrizza-ante per la stabilizzazione di ante scorrevoli.

It is recommended to use the straightening fitting for stabilizing sliding doors.

Pour stabiliser les portes coulissantes il est recommandé d'utiliser une ferrure du raidisseur de porte.

Ausrichtbeschlag zur Stabilisierung von Schiebetüren verwenden.

Para estabilizar las puertas correderas se recomienda utilizar un herraje de alineación.

**PB15 è compatibile con cerniere standard, ammortizzate, di diversi marchi facilmente reperibili sul mercato.**

### Caratteristiche della cerniera:

- collo 0
- angolo di apertura  $84^{\circ} \div 96^{\circ}$
- sormonto, a discrezione del cliente

PB15 is compatible with standard, soft-closing hinges of different brands that are easily available on the market.

### Features of the hinge:

- neck 0
- opening angle  $84^{\circ} \div 96^{\circ}$
- overlap, at customer's request

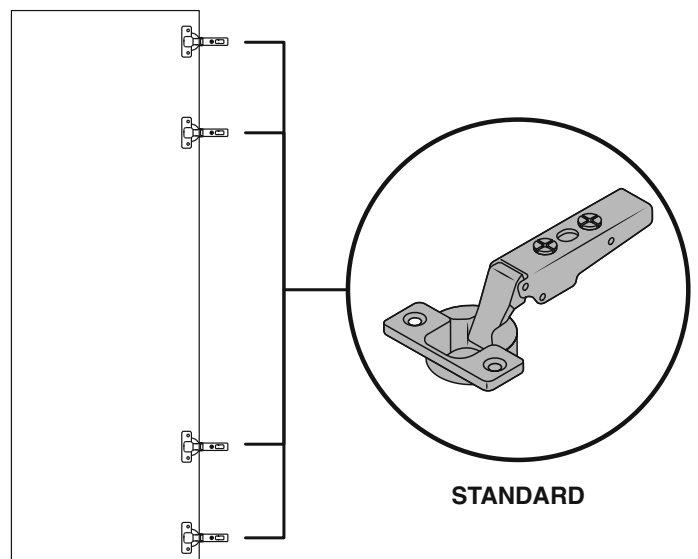

**ABBREVIAZIONI:**

- D** = profondità del fianco
- D1** = profondità del pannello di tamponamento
- H** = altezza del pannello di tamponamento
- H1** = altezza anta
- H2** = altezza fianco
- DW** = larghezza anta
- T** = spessore anta
- G** = mancato rientro
- O** = mancato sormonto sul cappello

**ABBREVIATIONS:**

- D** = side panel depth
- D1** = cover panel depth
- H** = cover panel height
- H1** = door height
- H2** = side height
- DW** = door width
- T** = door thickness
- G** = missing entrance
- O** = portion of the top panel, not overlapped by the door

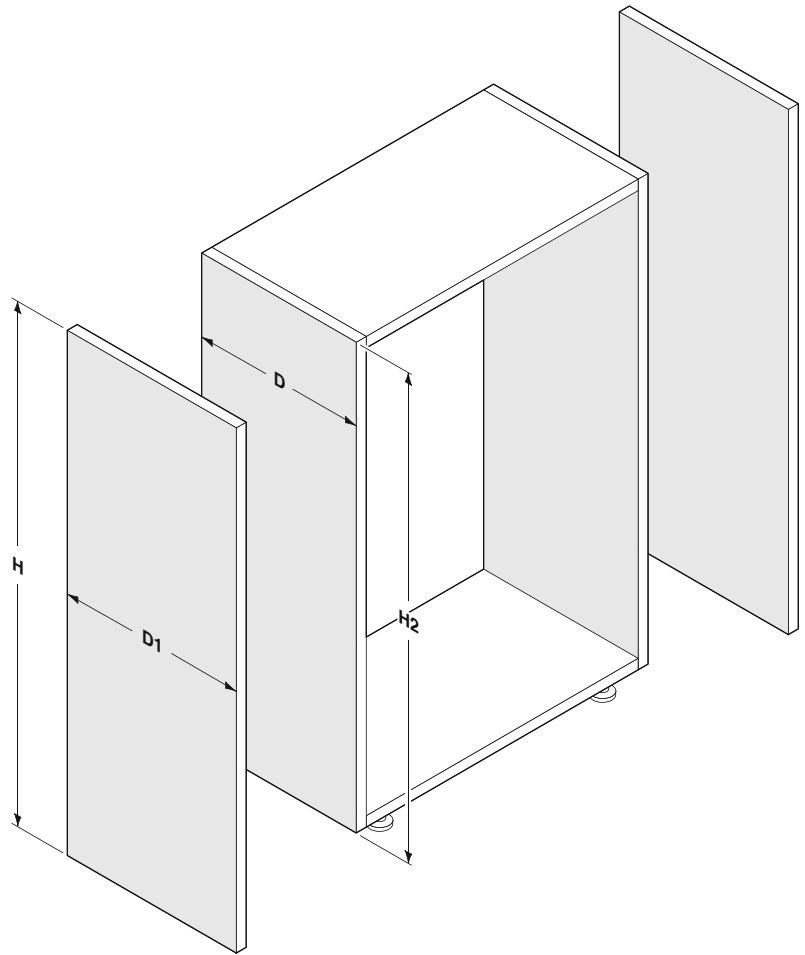

$$G = (DW - D) + 188,5$$

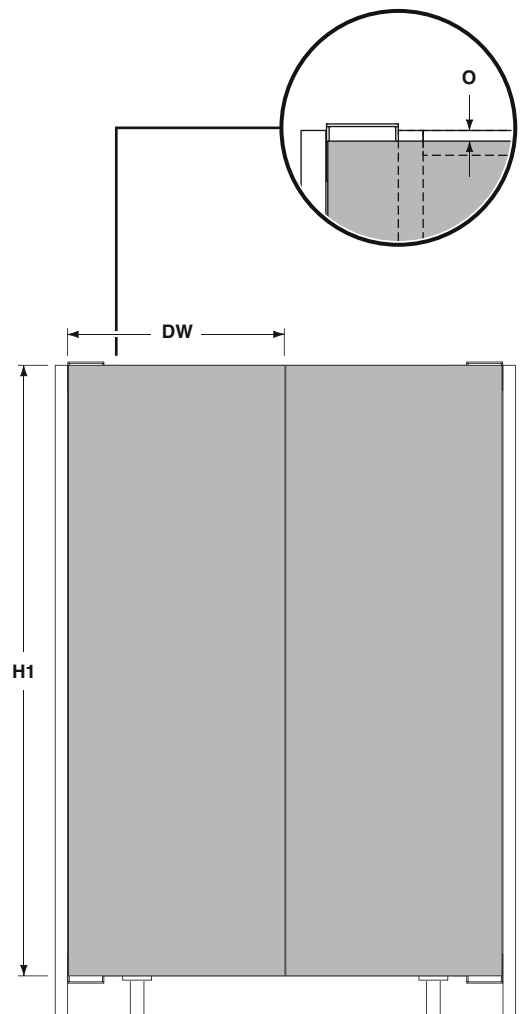
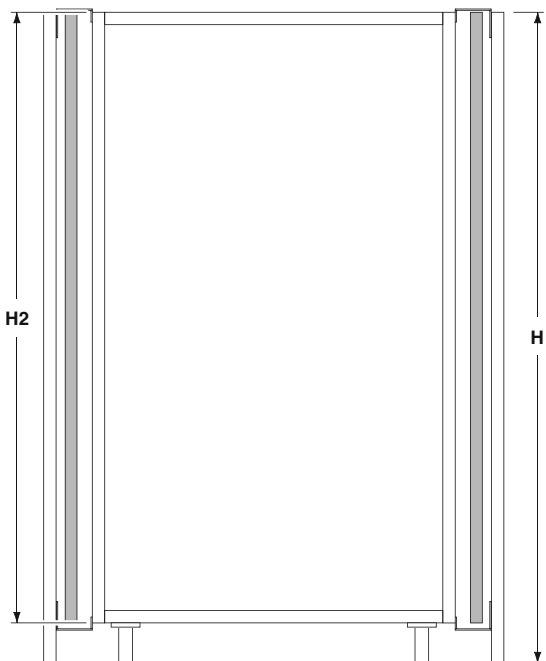

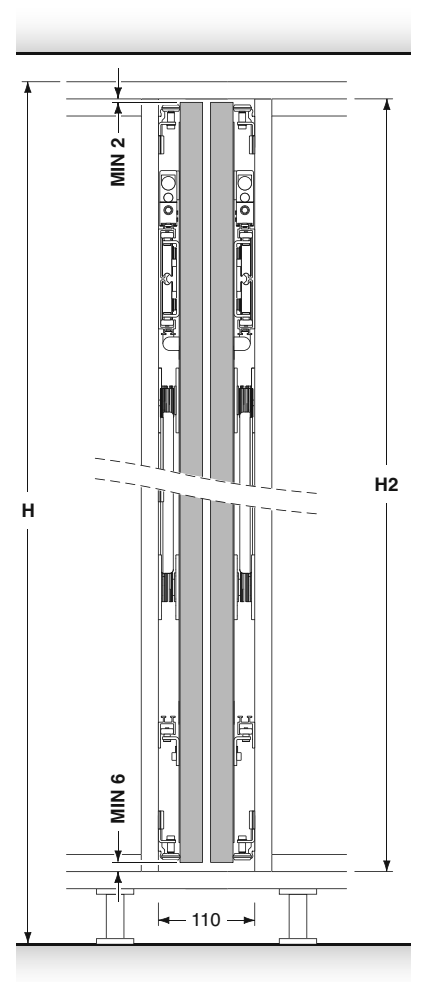
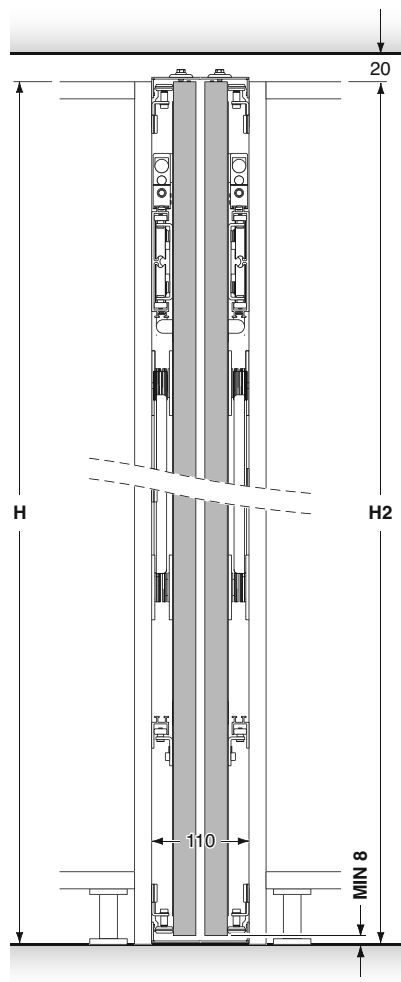
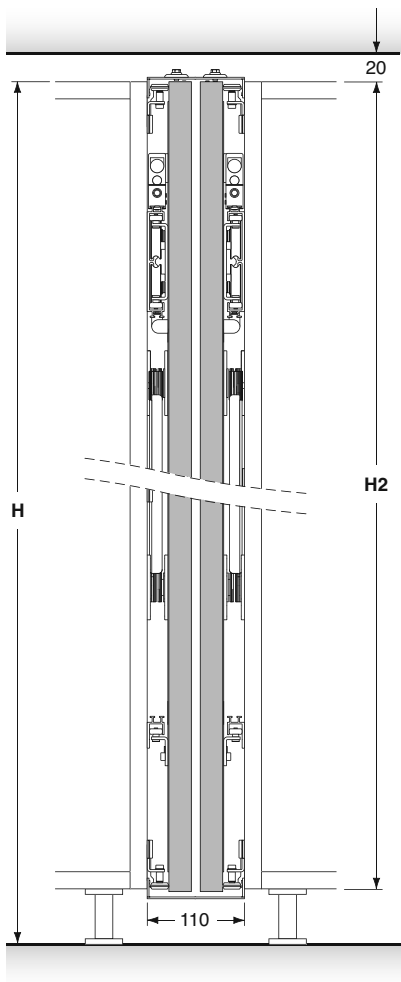
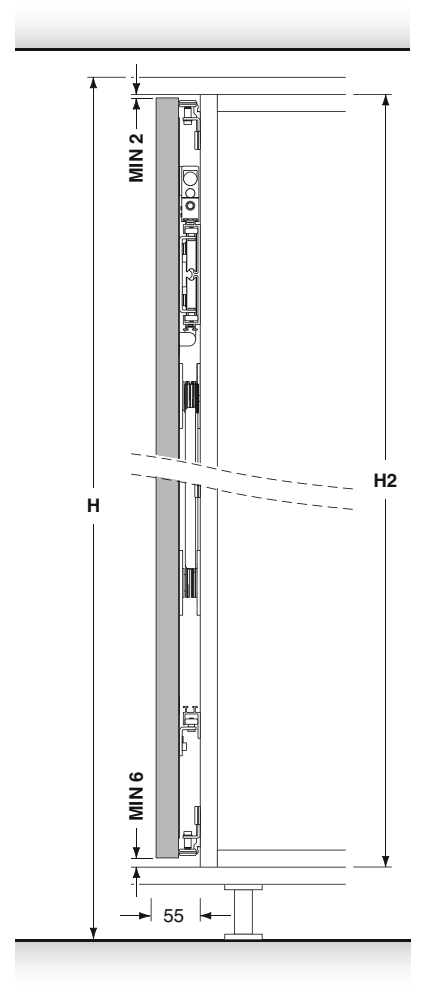
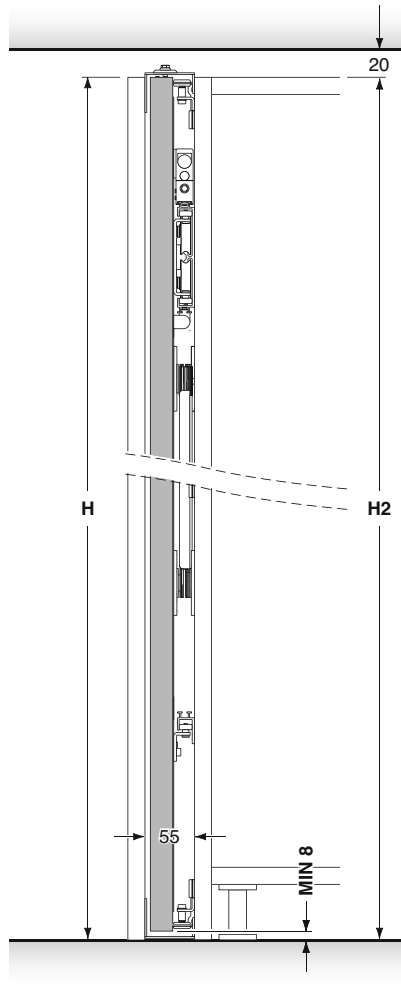
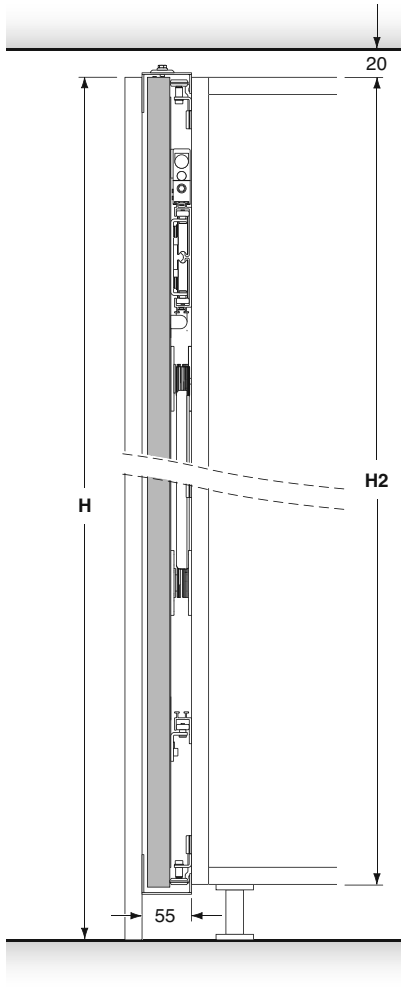

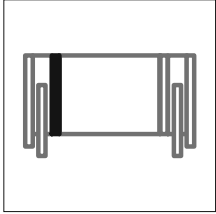

**Lavorazioni per il fianco sx 550÷750 mm.**

Working requests for the left side 550÷750 mm.

Usinage pour le côté gauche 550÷750 mm.

Bearbeitung für Innenseite links 550÷750 mm.

Esquema de perforación para el costado izquierdo 550÷750.

**Fianco destro: speculare**

Right side: mirror-like

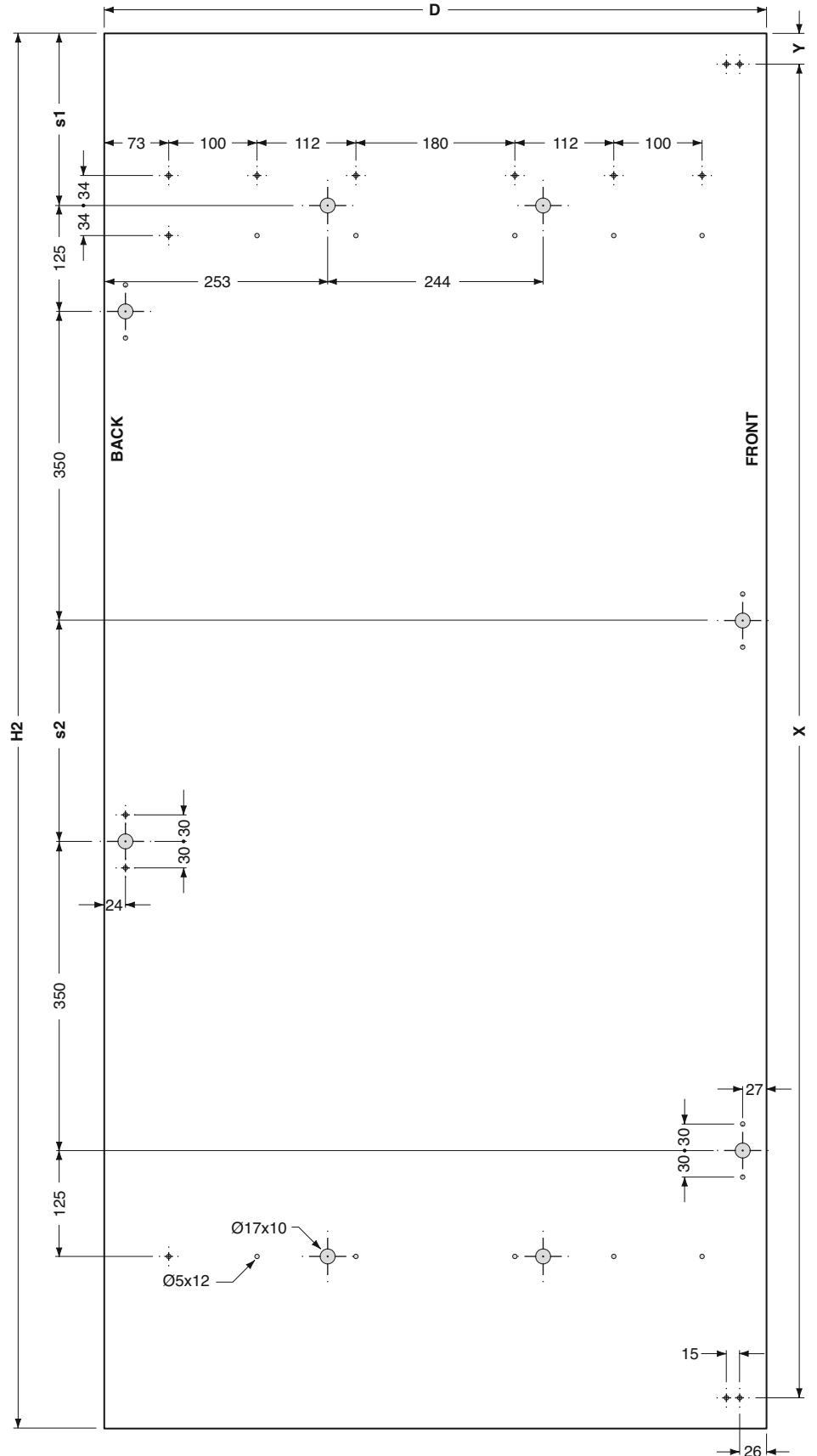

Y	32 + O
X	H1 - 64
s1	H1 1600÷2000 = H1 / 2 - 600 + O H1 2000÷2400 = H1 / 2 - 800 + O H1 2400÷2800 = H1 / 2 - 1000 + O
s2	H1 1600÷2000 = 250 H1 2000÷2400 = 650 H1 2400÷2800 = 1050

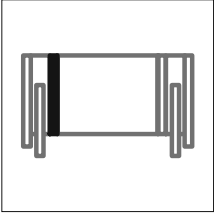

**Lavorazioni per il fianco sx 750÷1000 mm.**

Working requests for the left side 750÷1000 mm.

Usinage pour le côté gauche 750÷1000 mm.

Bearbeitung für Innenseite linksm 750÷1000 mm.

Esquema de perforación para el costado izquierdo 750÷1000 mm.

**Fianco destro: speculare**

Right side: mirror-like

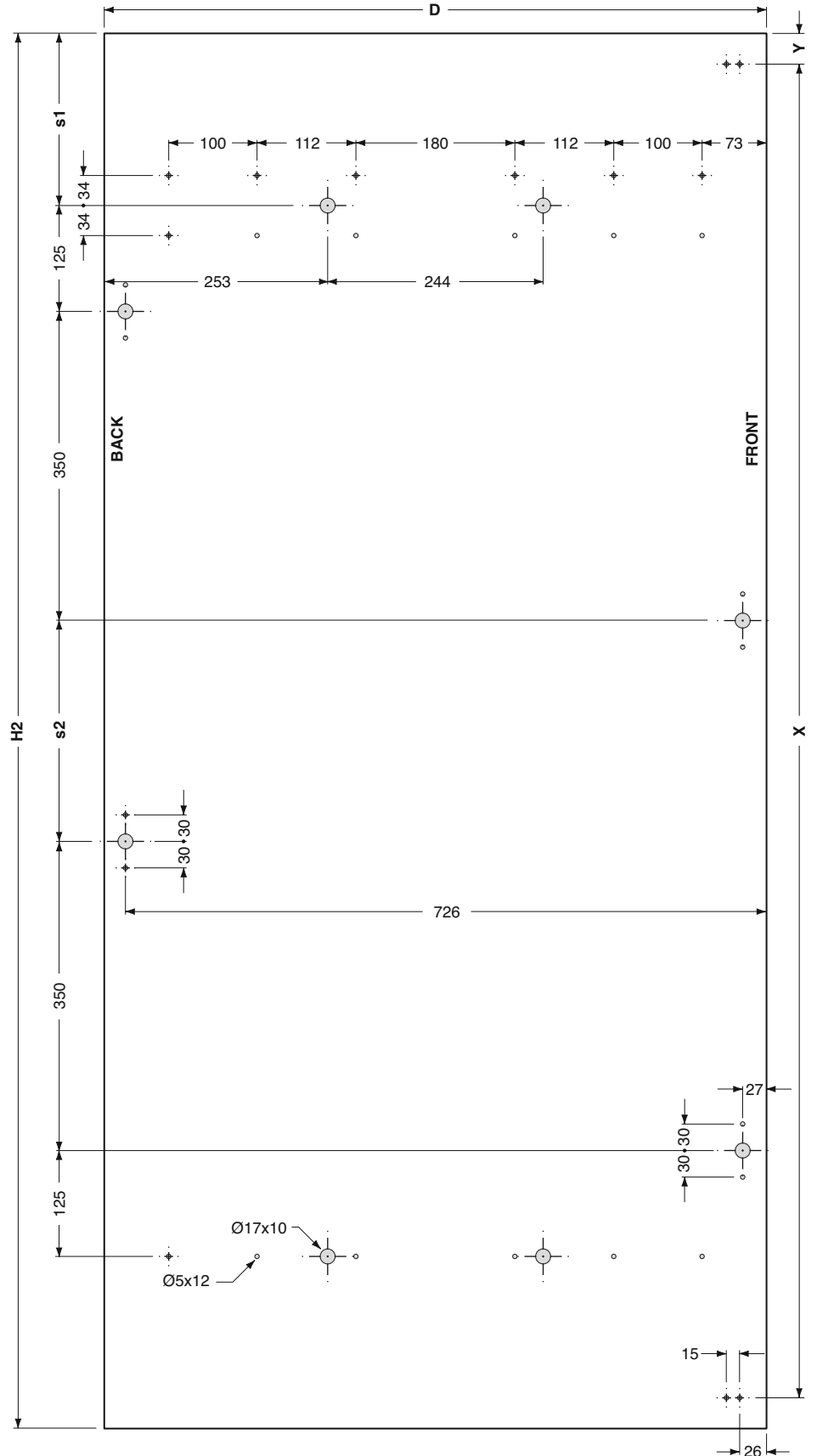

<b>Y</b>	32 + O
<b>X</b>	H1 - 64
<b>s1</b>	H1 1600÷2000 = H1 / 2 - 600 + O H1 2000÷2400 = H1 / 2 - 800 + O H1 2400÷2800 = H1 / 2 - 1000 + O
<b>s2</b>	H1 1600÷2000 = 250 H1 2000÷2400 = 650 H1 2400÷2800 = 1050

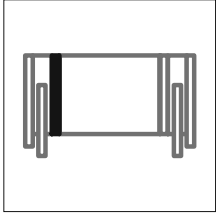

**Lavorazioni aggiuntive per il fianco sx in caso di applicazione del profilo cover.**

Additional machining for the left side with cover profile.

Usinage supplémentaire du côté gauche en cas d'utilisation du profile de recouvrement.

Zusätzliche Bearbeitung bei Verwendung des Abdeckprofils links.

Mecanizados adicionales para el lado izquierdo en caso de aplicación del perfil de cobertura.

**Fianco destro: speculare**

Right side: mirror-like

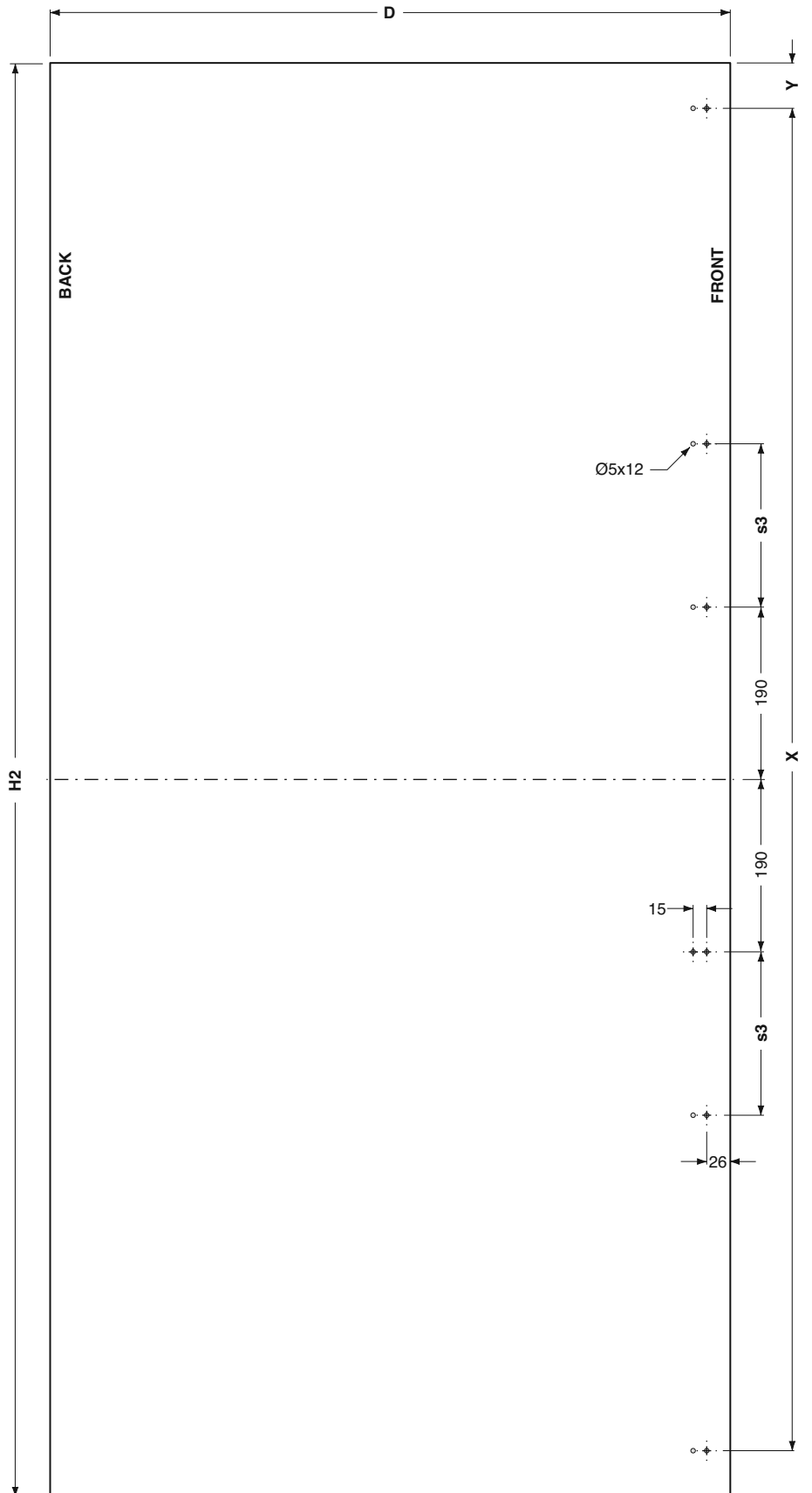

Y	47 + O
X	H1 - 94
s3	H1 1600÷2000 = 180 H1 2000÷2400 = 380 H1 2400÷2800 = 580

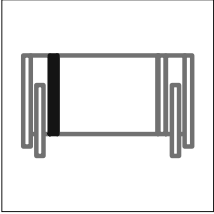

**Lavorazioni aggiuntive per il fianco sx in caso di applicazione staffe laterali.**

Additional machining for the left side with lateral bracket connector.

Usinage supplémentaire du côté gauche en cas d'utilisation du connecteur latéral.

Zusätzliche Bearbeitung bei Verwendung des Verbindungprofils links.

Mecanizados adicionales para el costado izquierdo en caso de aplicación de soportes laterales.

**Fianco destro: speculare**

Right side: mirror-like

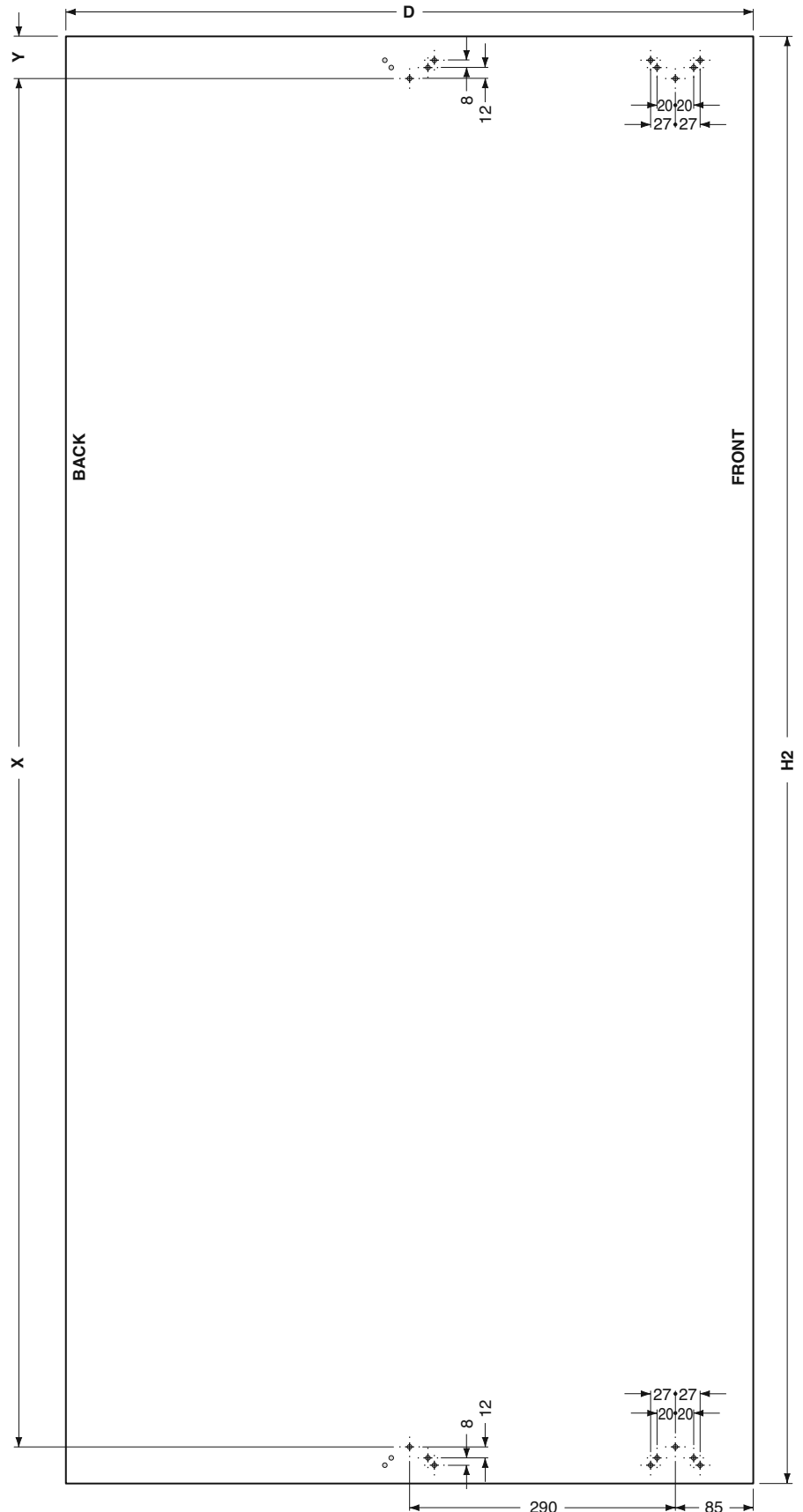

<b>Y</b>	46 + O
<b>X</b>	H1 - 89

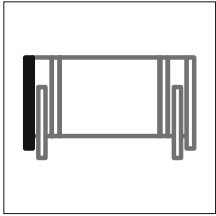

**Lavorazioni per il pannello di tamponamento sx.**

Working for the left cover panel.

Usinage du panneau de recouvrement Gauche.

Bearbeitung für Aussenseite links.

Mecanizados para el panel de cobertura izquierdo.

**Pannello di copertura destro:  
speculare**

Cover right panel: mirror-like

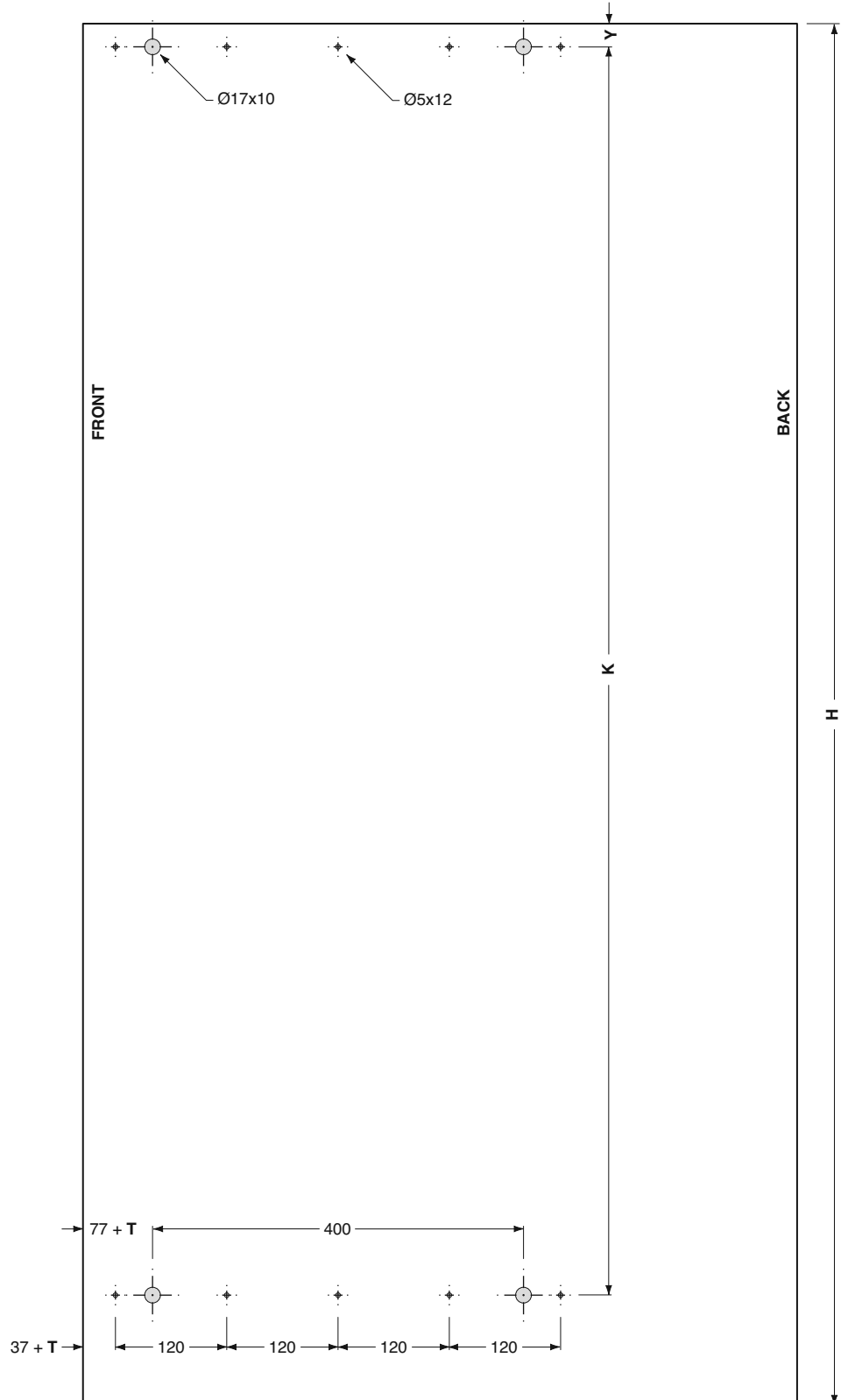
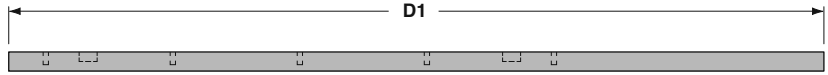

<b>Y</b>	25 + O
<b>K</b>	H1 - 47
<b>T</b>	spessore anta / door thickness
<b>D1</b>	D + 2 + T

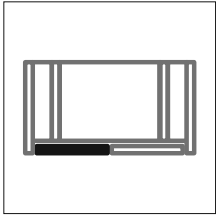

**Lavorazioni per l'anta sx.**

Working for the left door.  
 Usinage de la porte gauche.  
 Bearbeitung für Tür links.  
 Mecanizados para la puerta izquierda.

**Anta destra: speculare**  
 Right door: mirror-like

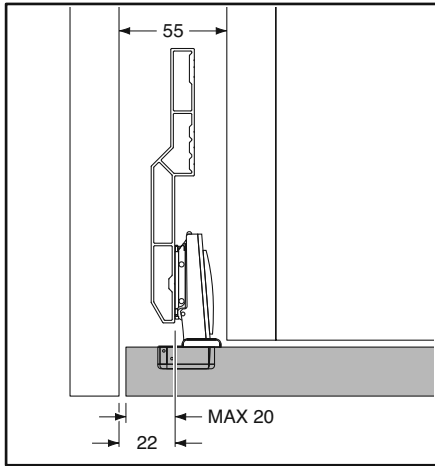
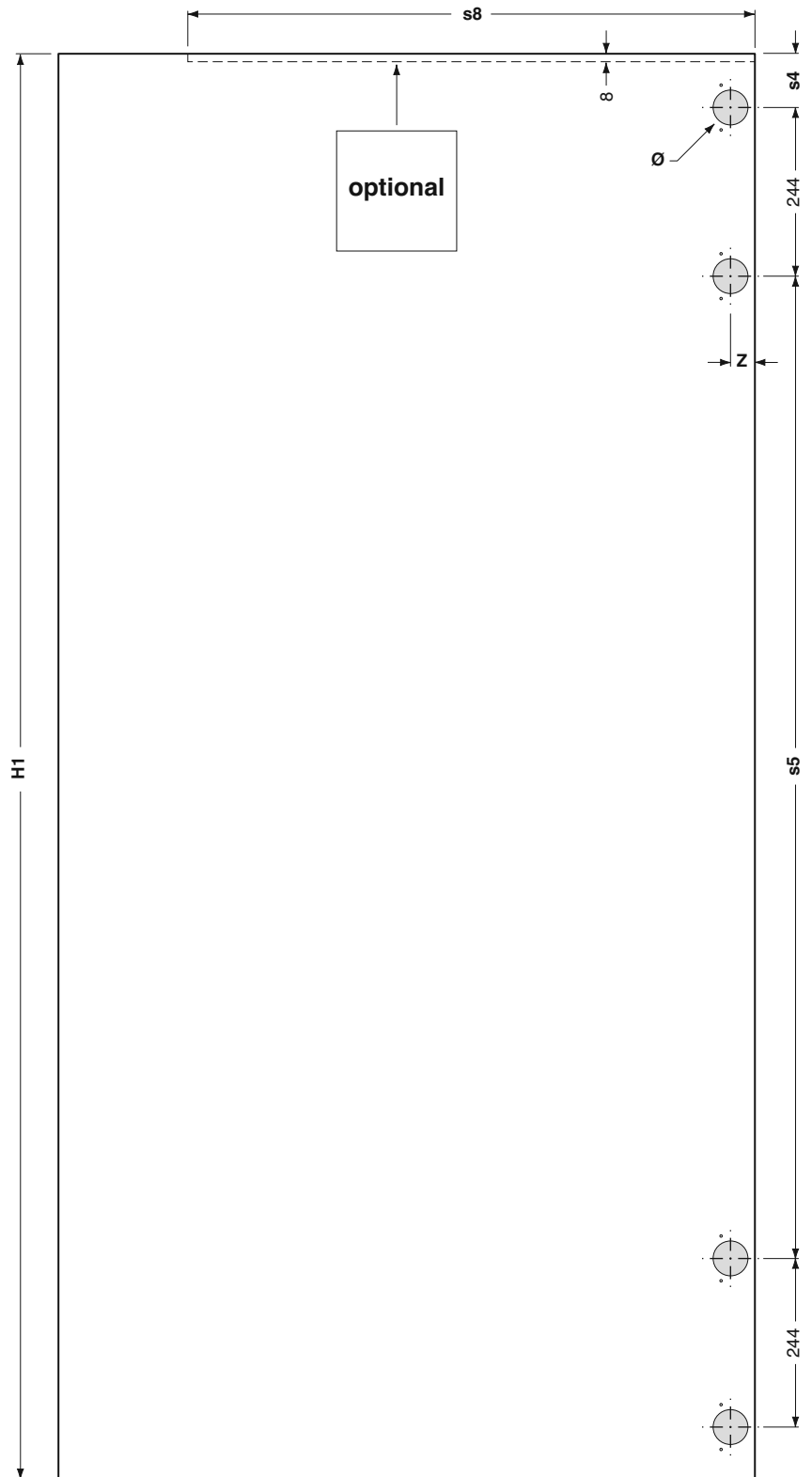

<b>s4</b>	H1 1600÷2000 = H1 / 2 - 750 H1 2000÷2400 = H1 / 2 - 950 H1 2400÷2800 = H1 / 2 - 1150
<b>s5</b>	H1 1600÷2000 = 1012 H1 2000÷2400 = 1412 H1 2400÷2800 = 1812
<b>s8</b>	DW ≥ 600 = 580 DW < 600 = DW - 20
<b>Z, Ø</b>	<b>Queste quote dipendono dalla cerniera scelta.</b> These dimensions change according to the hinges used.

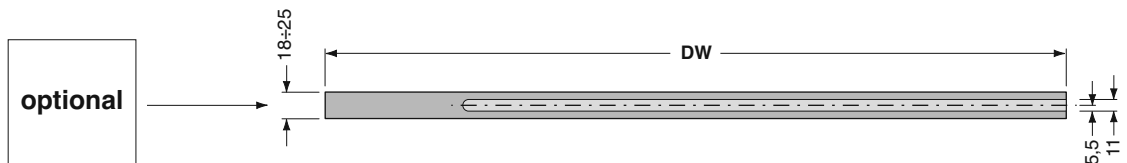

### Taglio a misura del profilo cover frontale sx.

Cut on size the front left cover.

Coupe à dimension du cache frontal gauche.

Linken Frontdichtung ablängen.

Corte a medida del perfil de cobertura frontal izquierdo.

s6	H1 1600+2000 = H1 / 2 - 758
	H1 2000+2400 = H1 / 2 - 958
	H1 2400+2800 = H1 / 2 - 1158
s7	H1 1600+2000 = 990
	H1 2000+2400 = 1390
	H1 2400+2800 = 1790

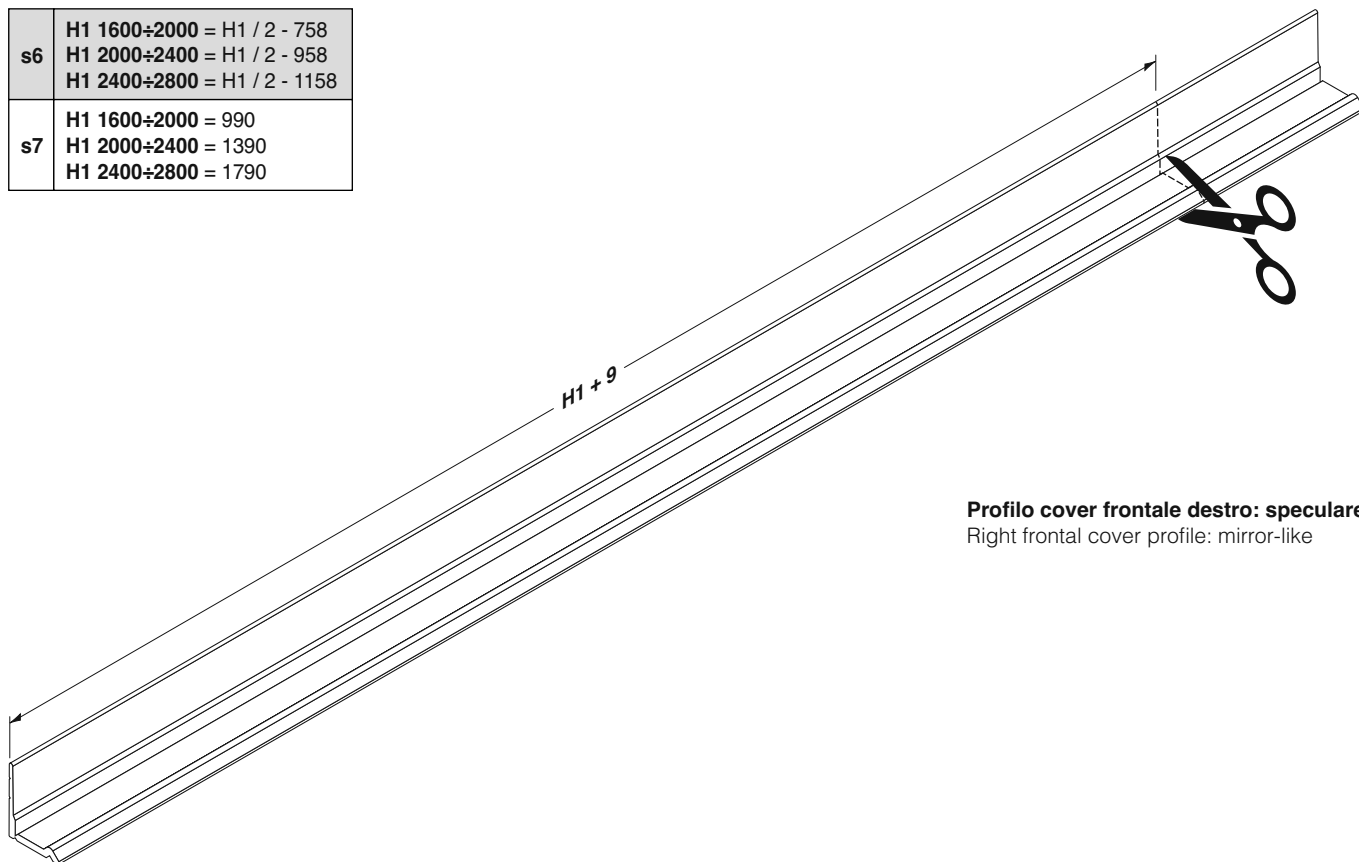

**Profilo cover frontale destro: speculare**  
Right frontal cover profile: mirror-like

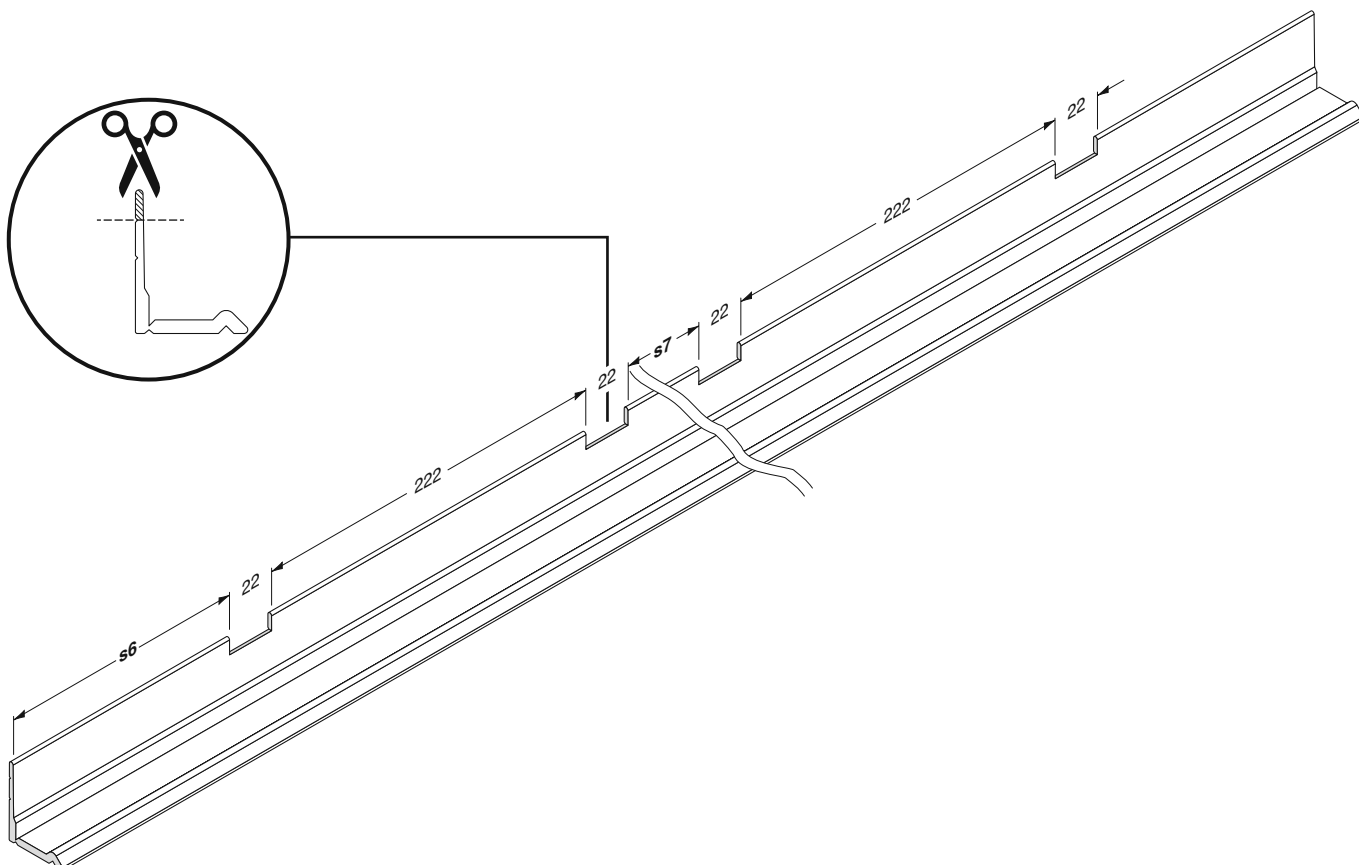

## Taglio a misura dei binari.

Cut on size of the rails.

Coupe à dimension des profils.

Schienen ablängen.

Corte a medida de los rieles.

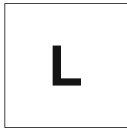

### I binari devono essere tagliati sempre nella parte frontale.

Cut only front of the rails.

Les profils doivent être coupés depuis la partie avant.

Schienen vorne ablängen.

Los rieles deben ser siempre cortados en la parte frontal.

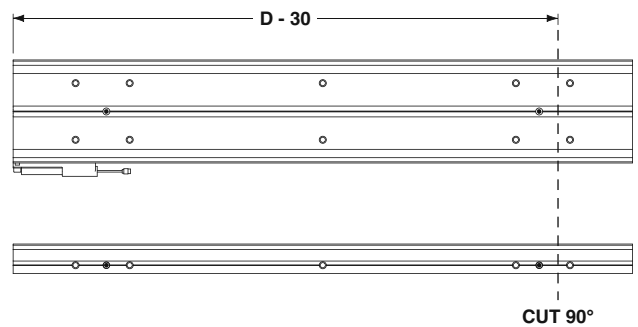
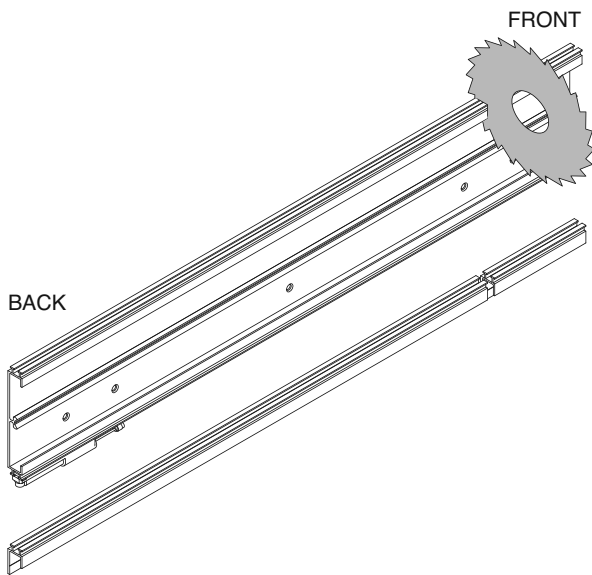

### I binari devono essere tagliati sempre nella parte frontale.

Cut only front of the tracks.

Les profils doivent être coupés depuis la partie avant.

Schienen vorne ablängen.

Los rieles deben ser siempre cortados en la parte frontal.

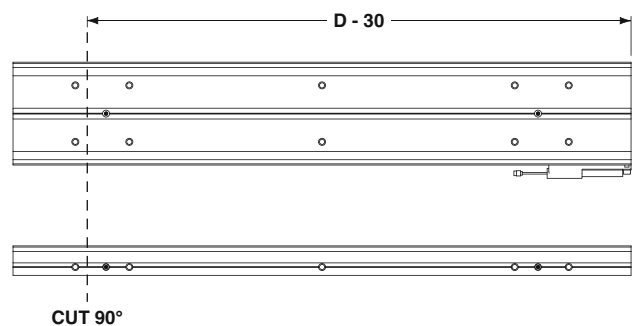
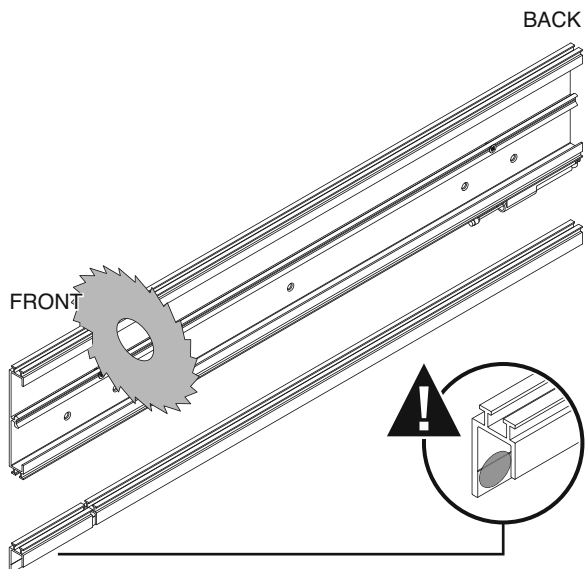

1

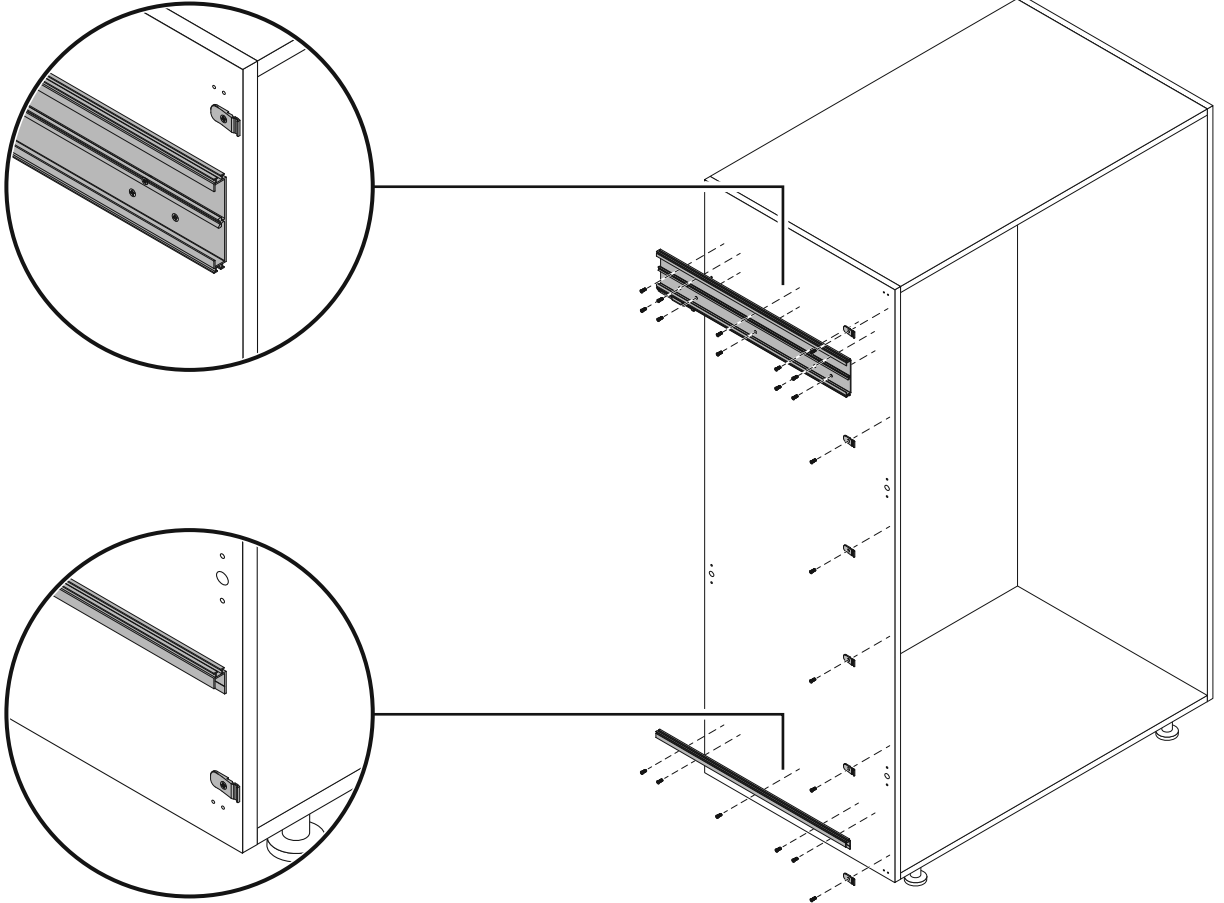

2



optional

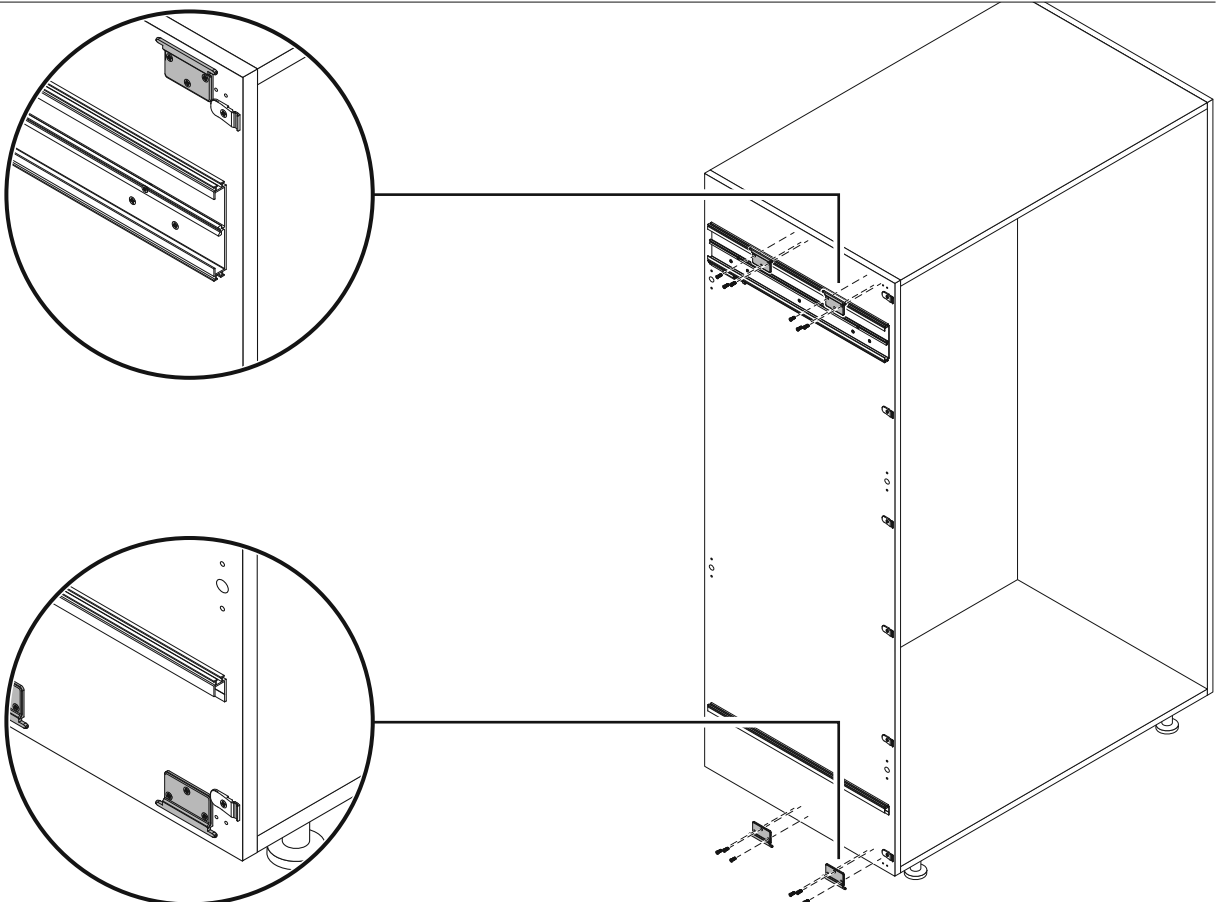

3

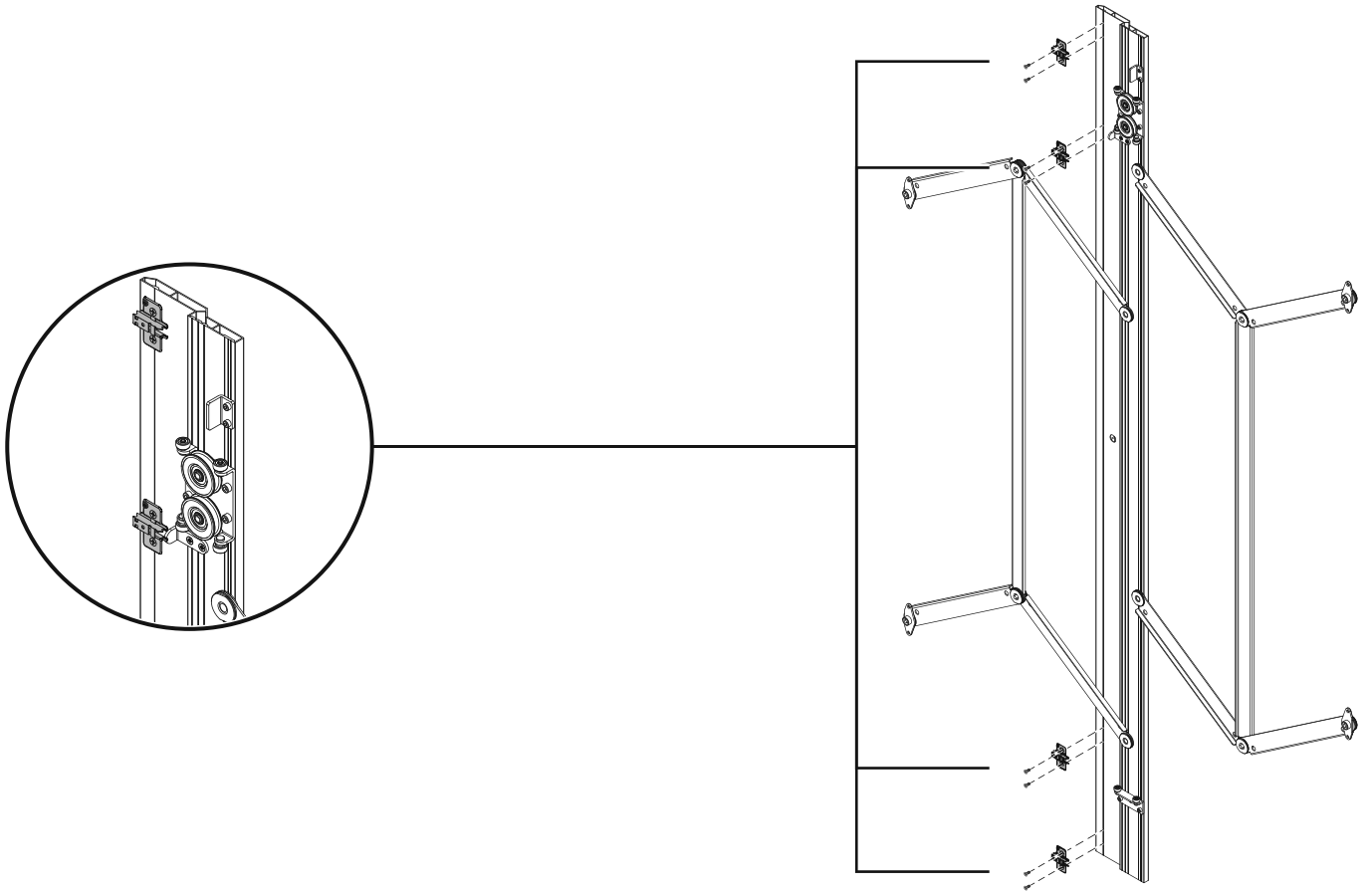

4

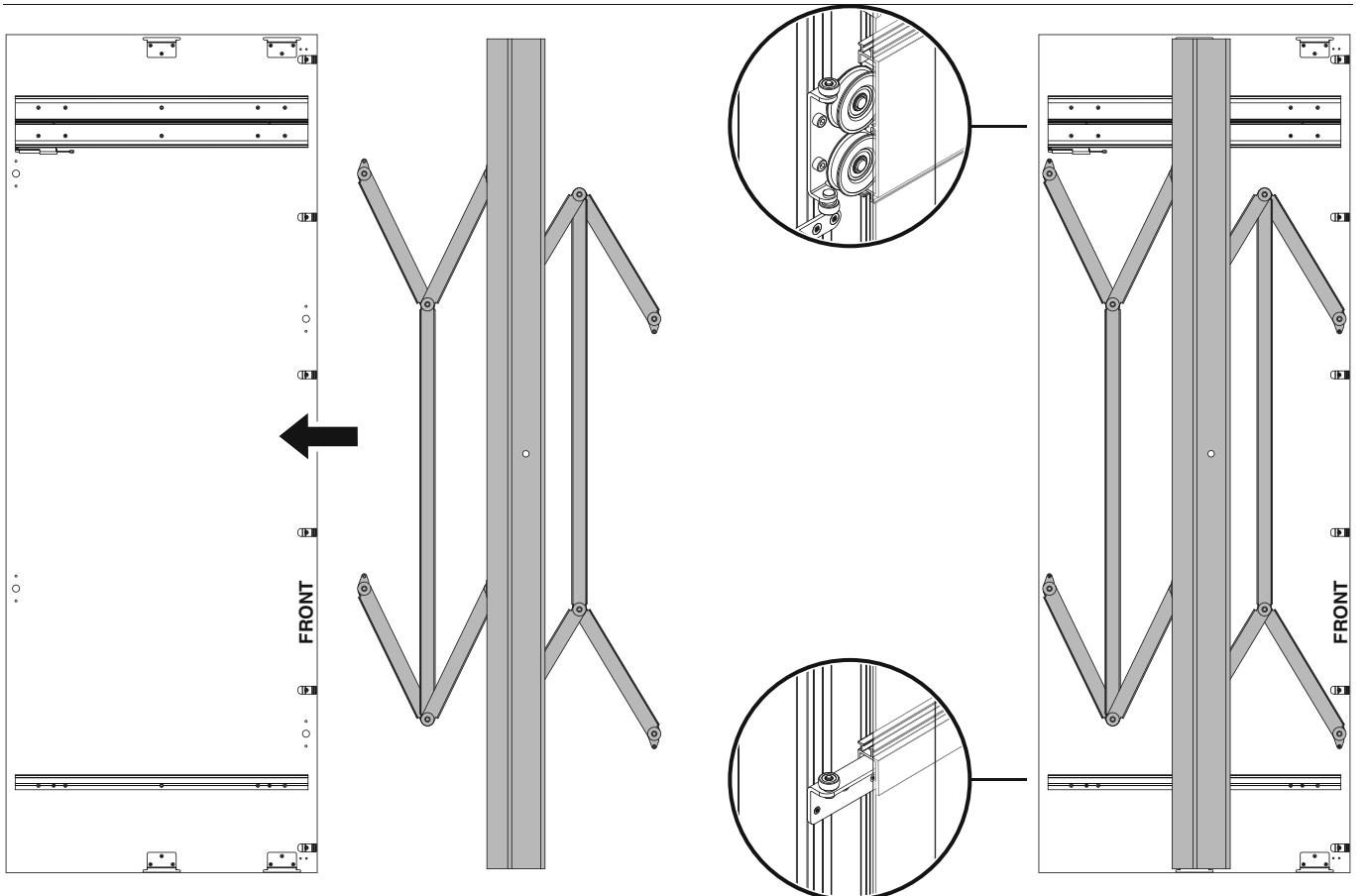

# 5

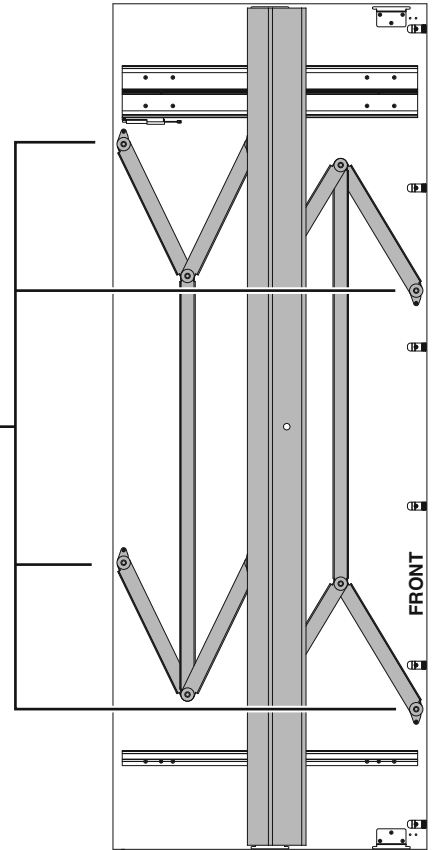
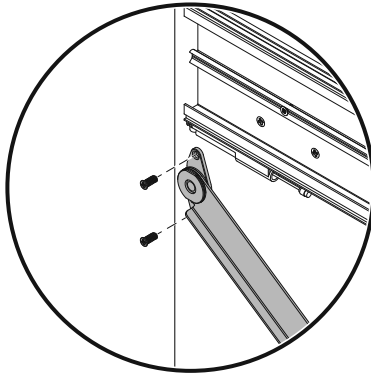

# 6

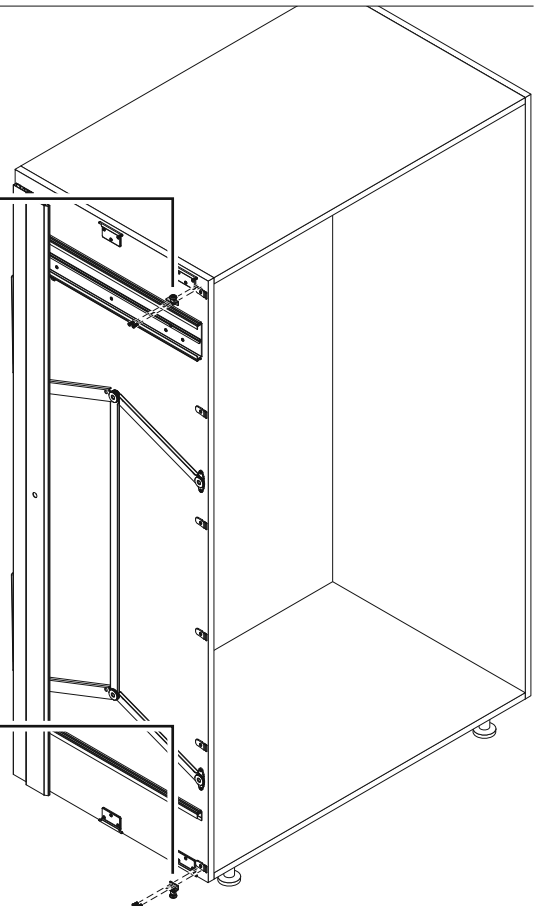
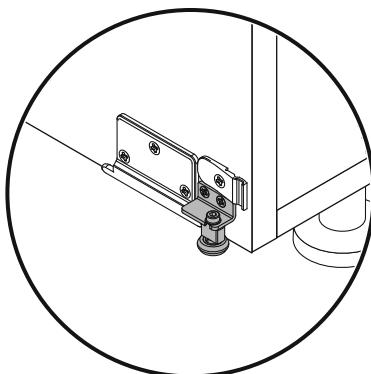
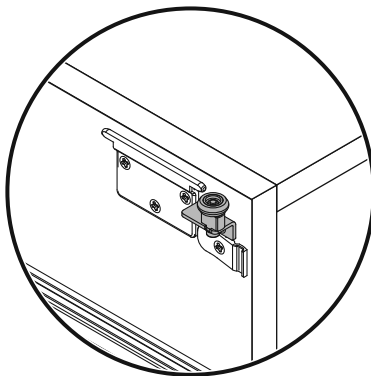

7

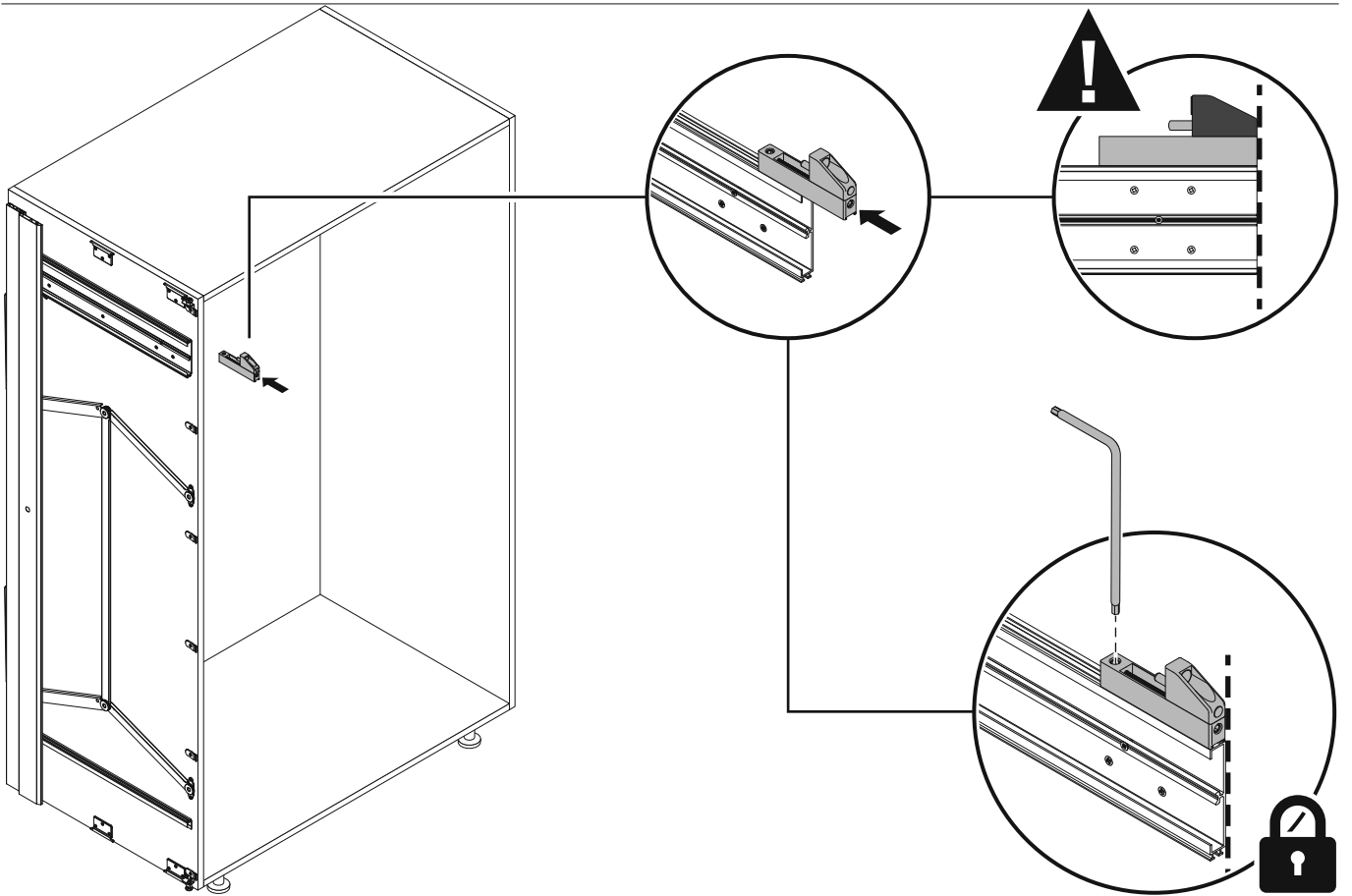

8

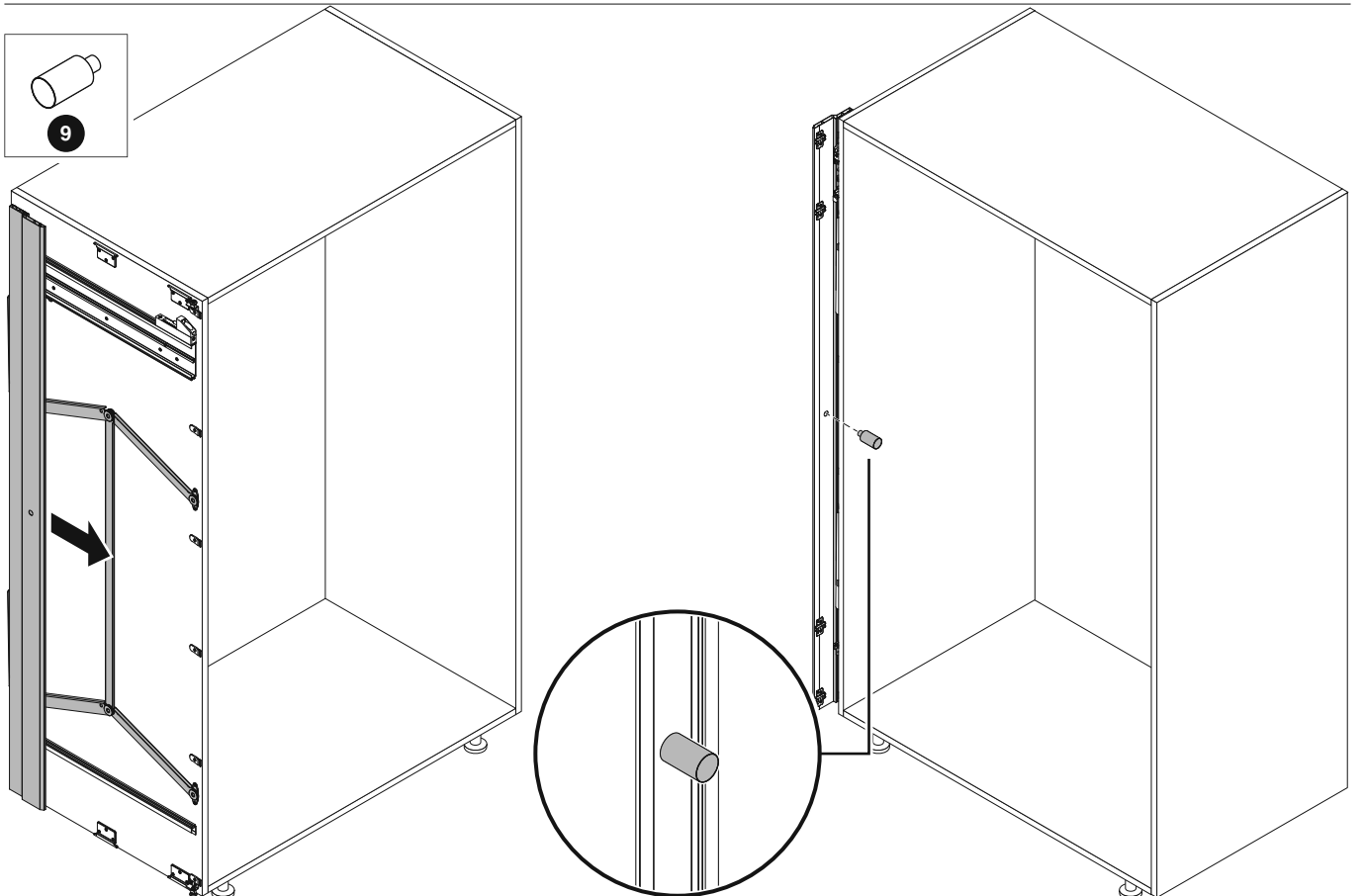

# 9

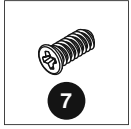
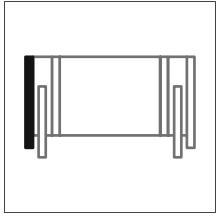

optional

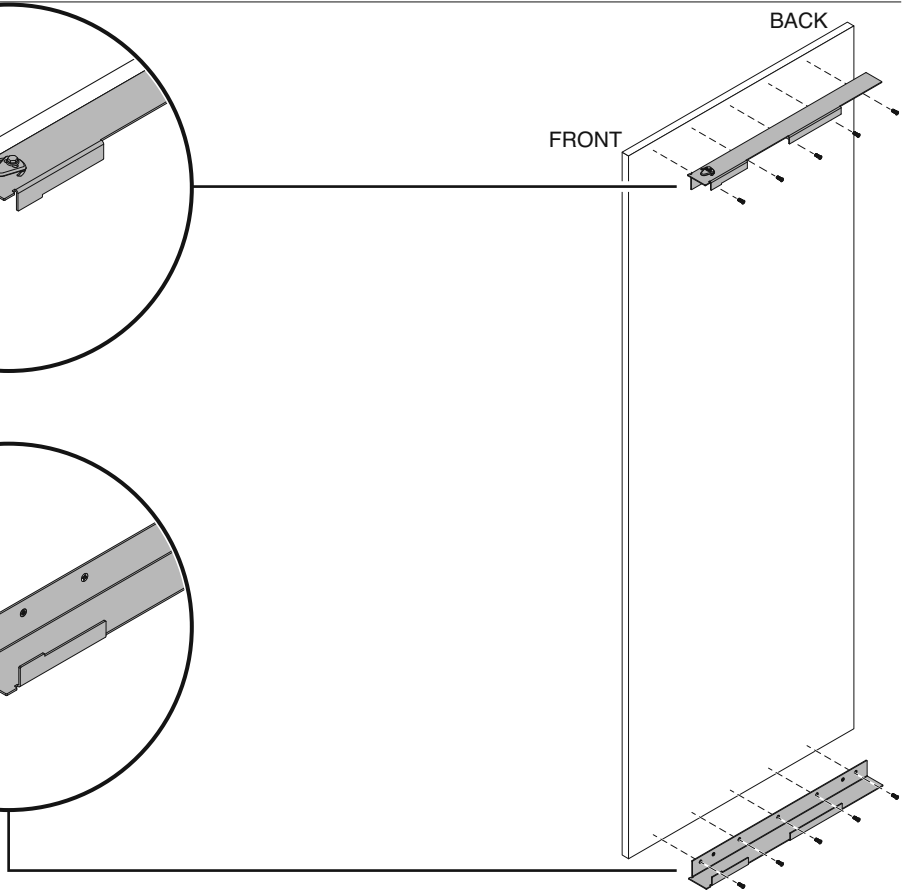
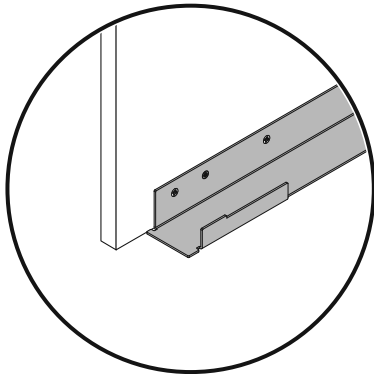
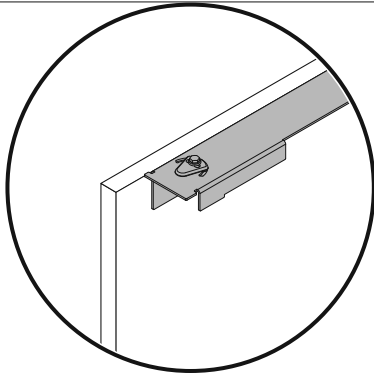

# 10

optional

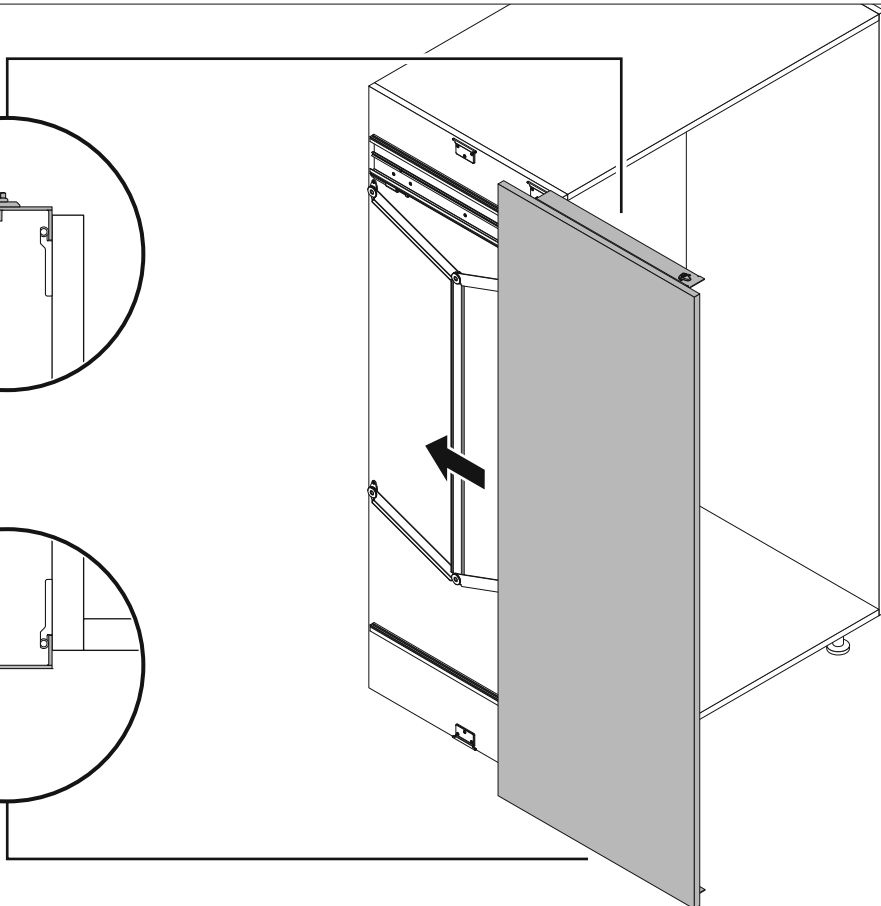
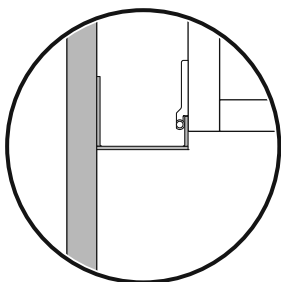
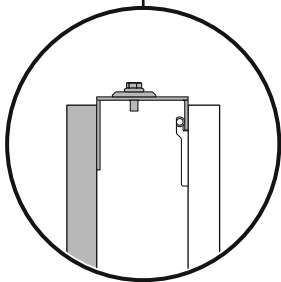

optional

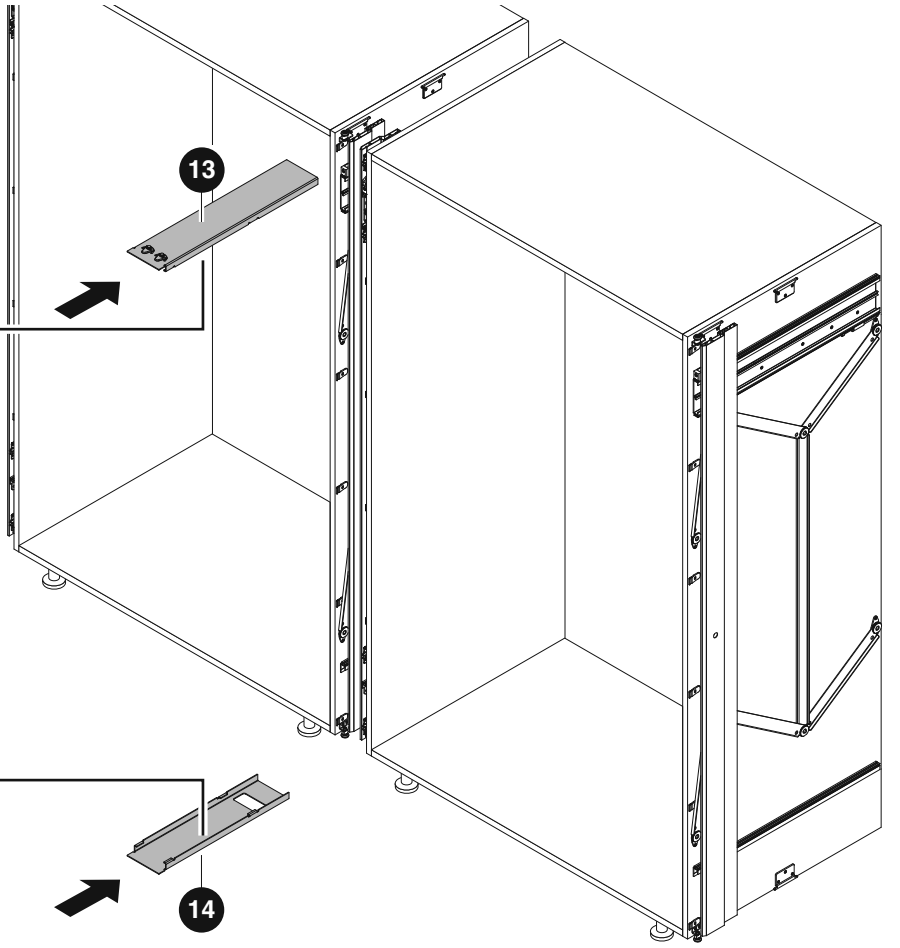
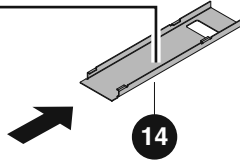
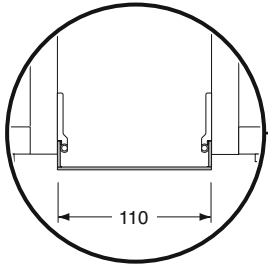
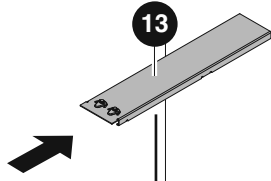
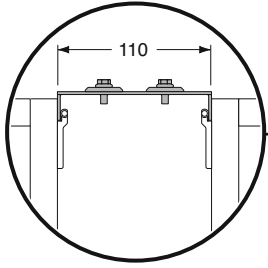

## Montaggio dell'anta.

Door installation.

Montage de la porte.

Türmontage.

Montaje de la puerta.

### Il profilo guida deve essere tagliato sempre nella parte frontale.

Cut only front of the door track profile.

Le profil guide doit être coupé en partie avant.

Führungsschiene vorne ablängen.

El perfil guía debe ser siempre cortado en la parte frontal.

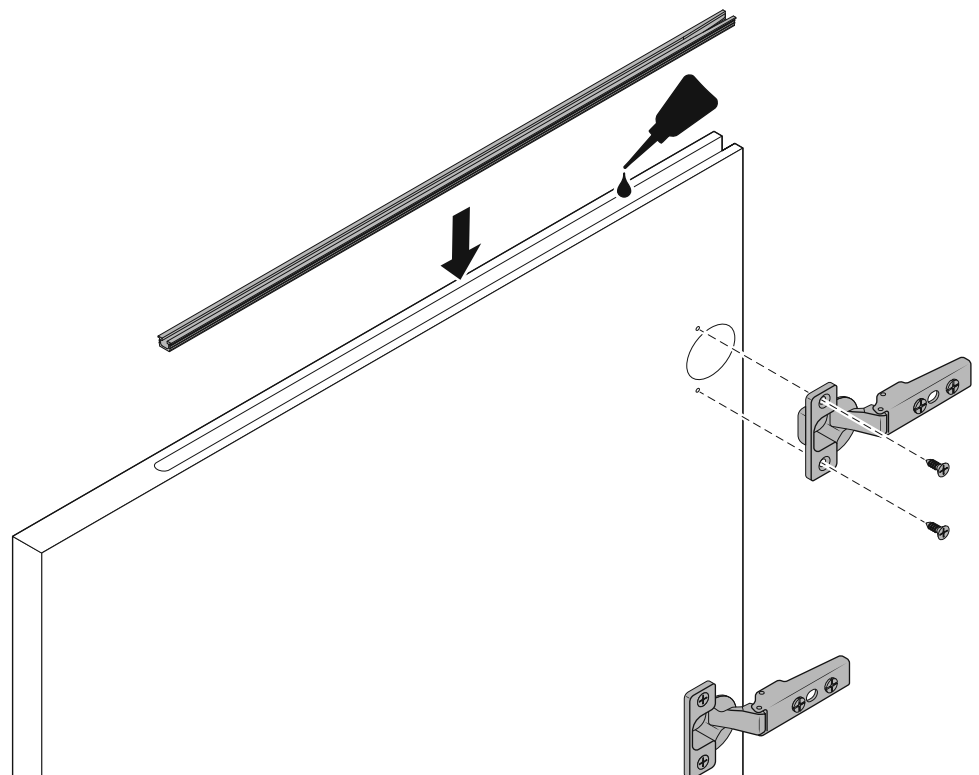
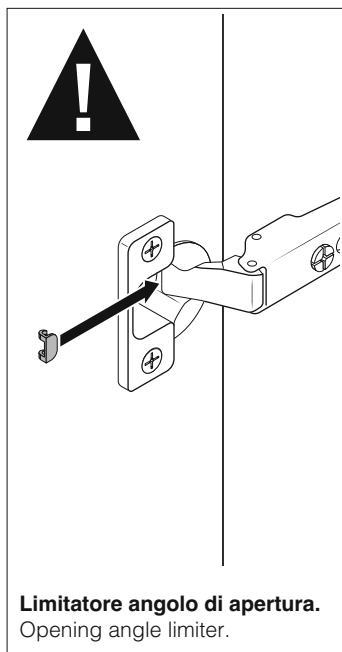
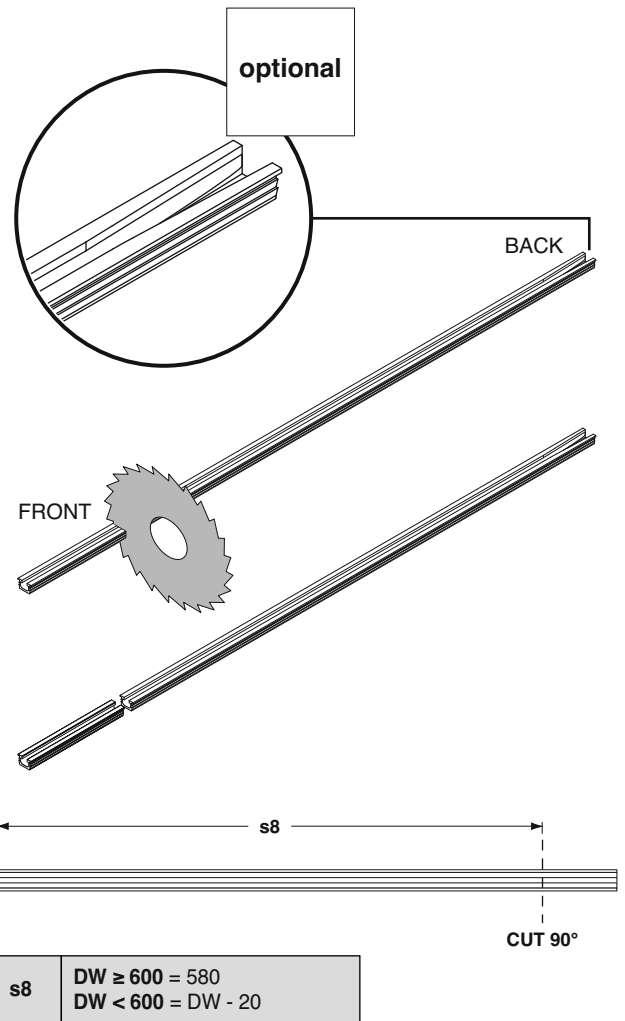
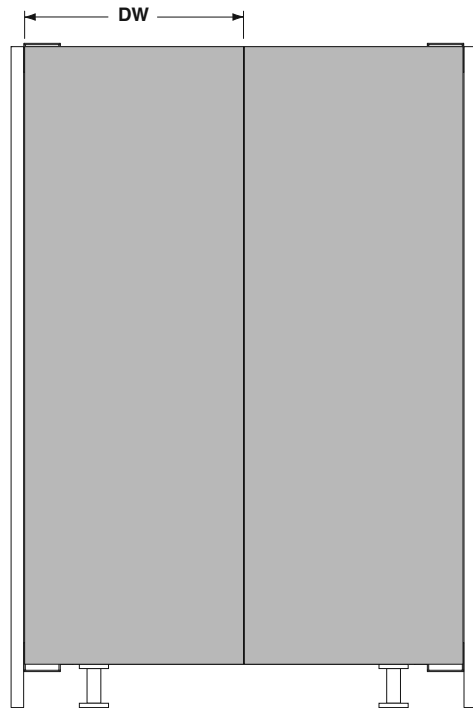

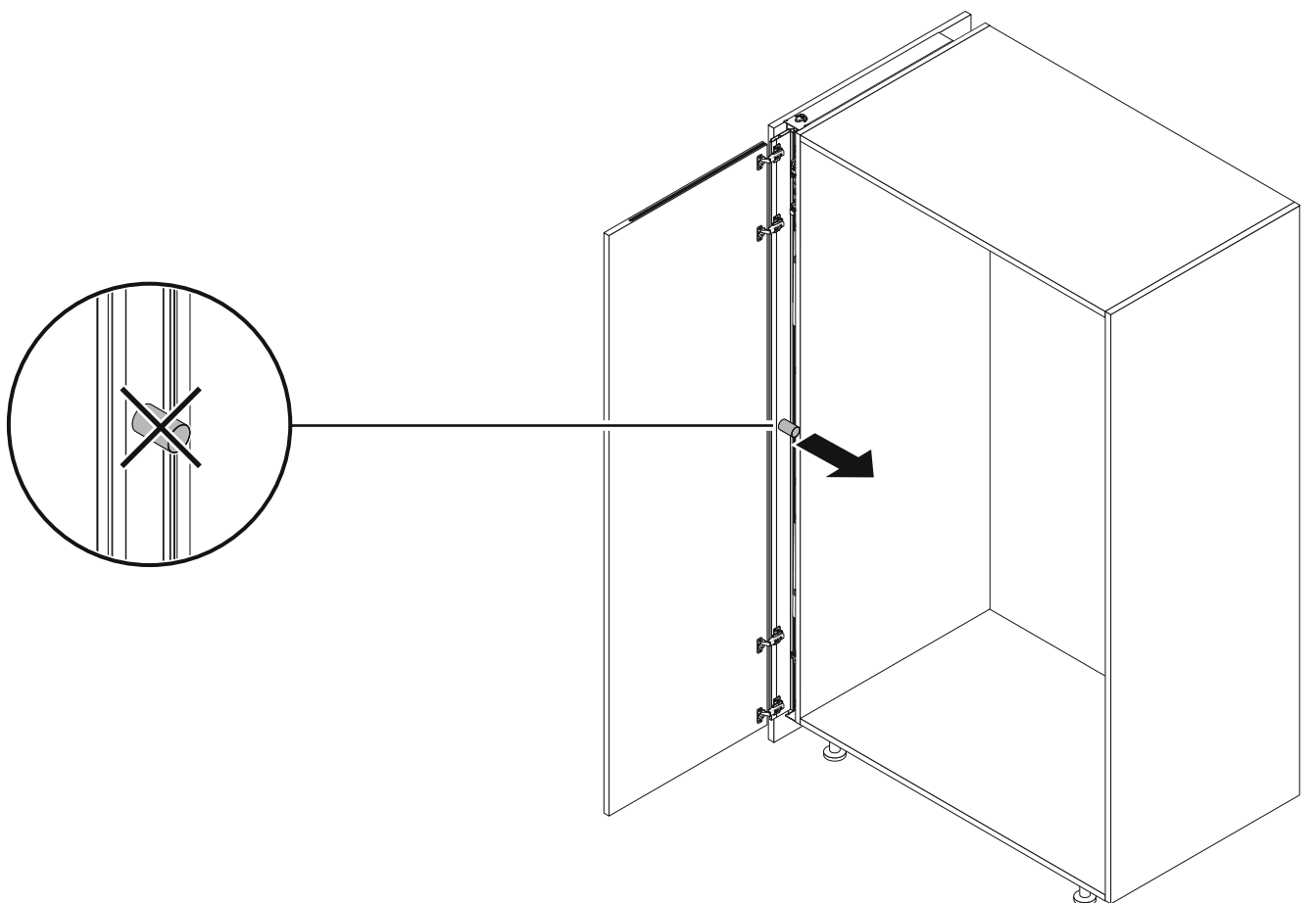
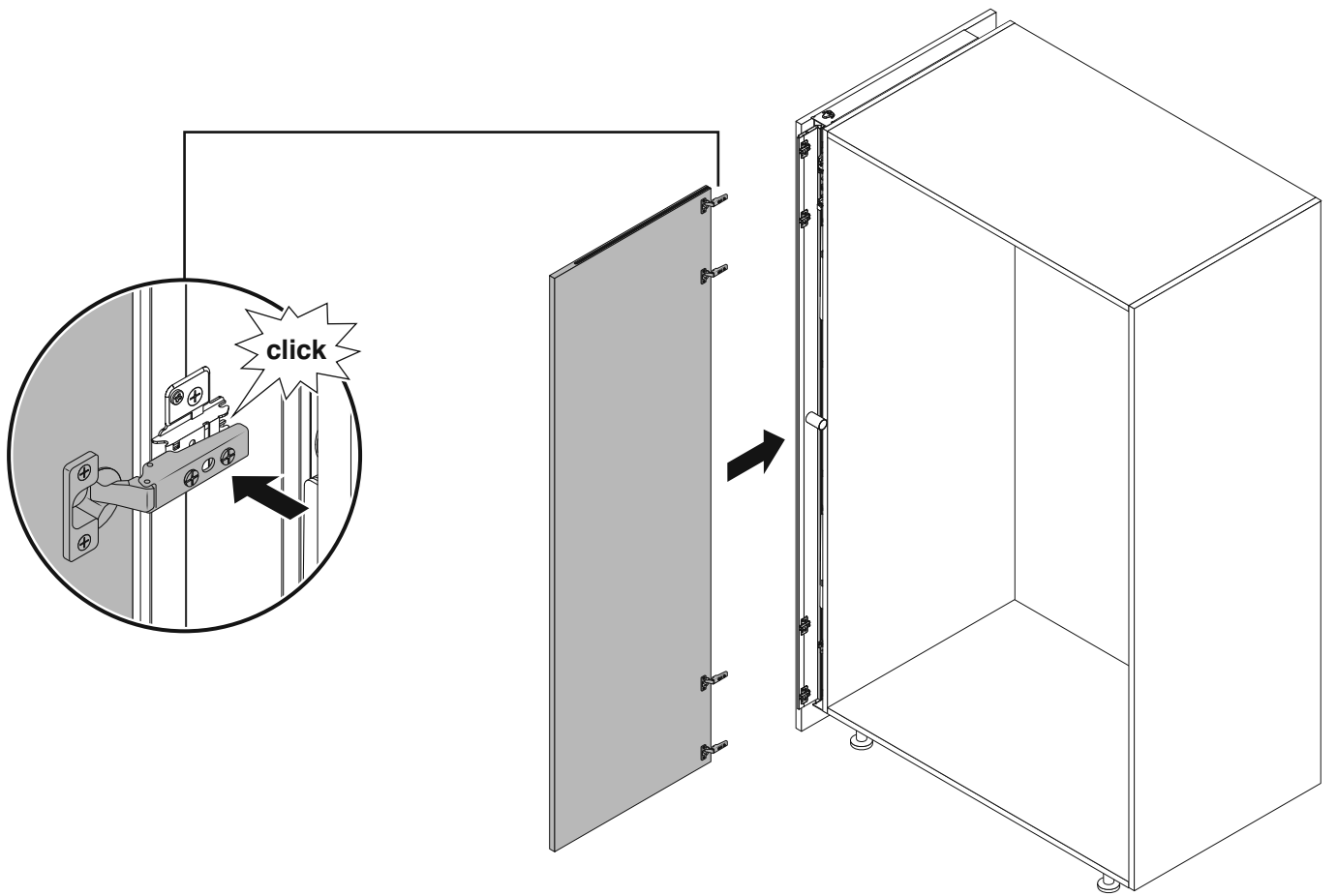

## Regolazioni dell'anta.

Door adjustment

Réglage de la port.

Tür einstellen.

Ajustes de la puerta.

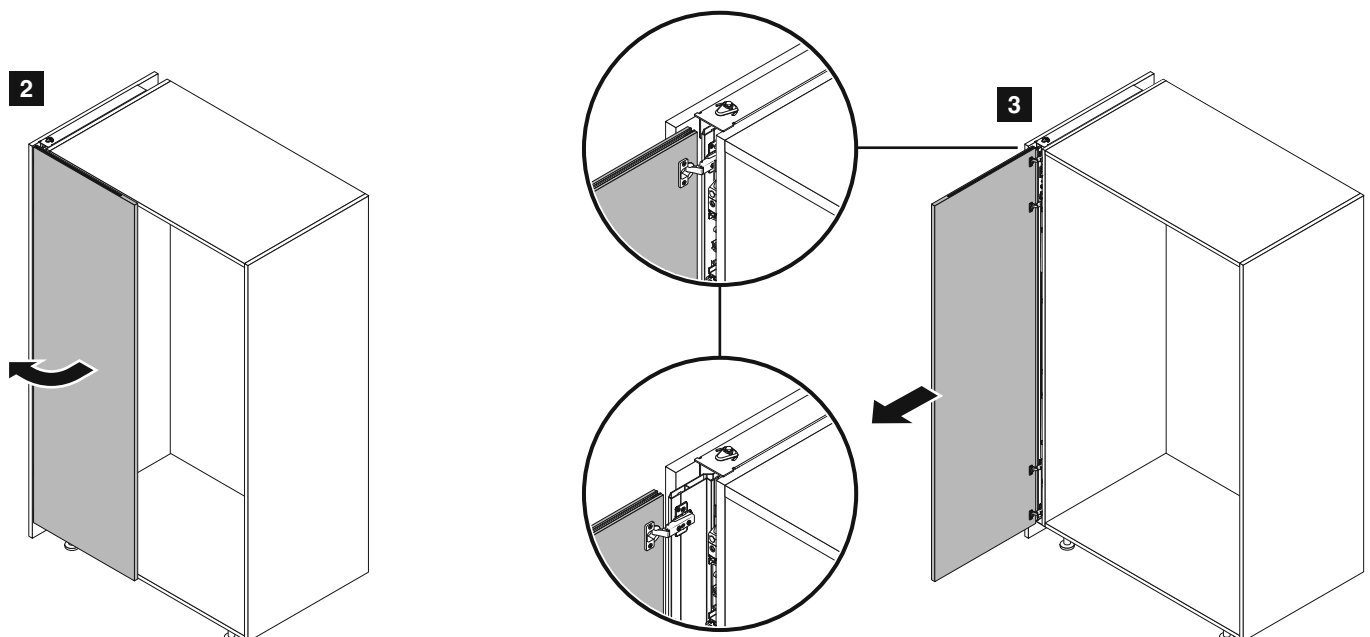
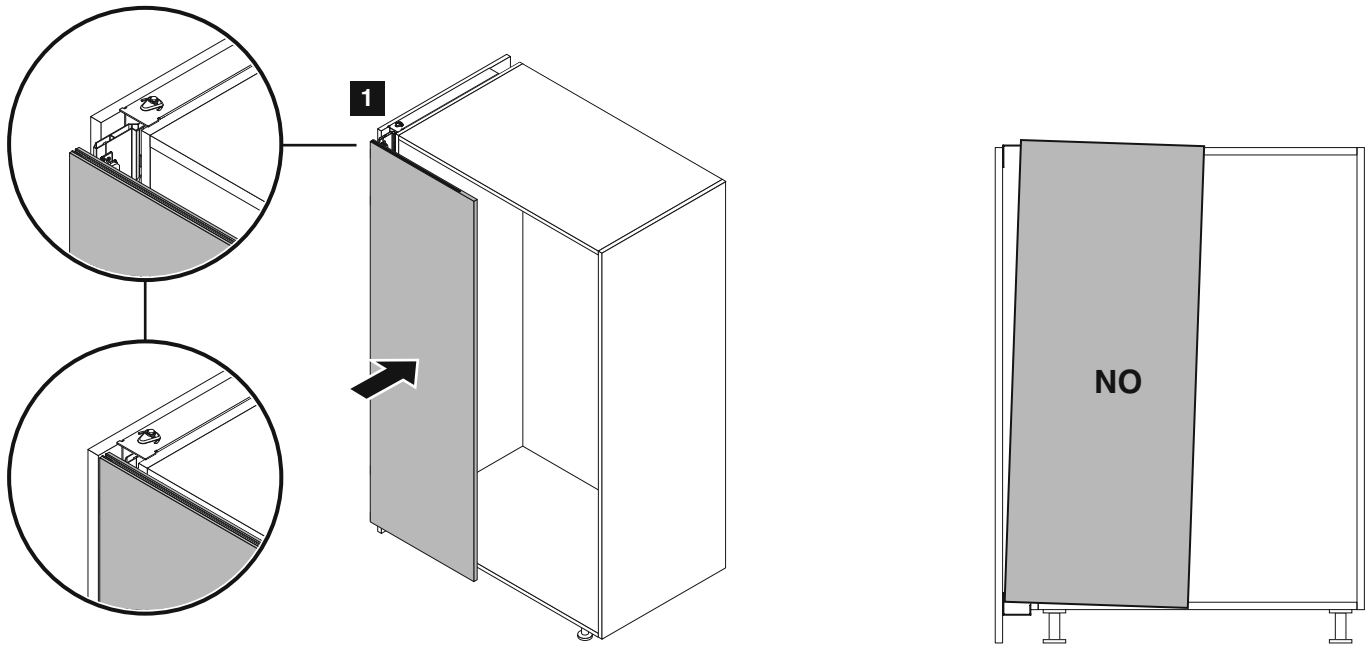

4

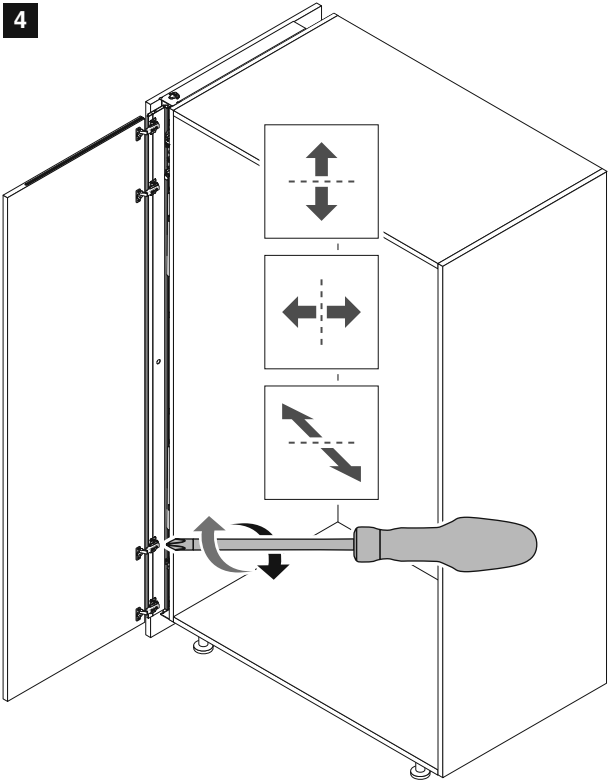

5

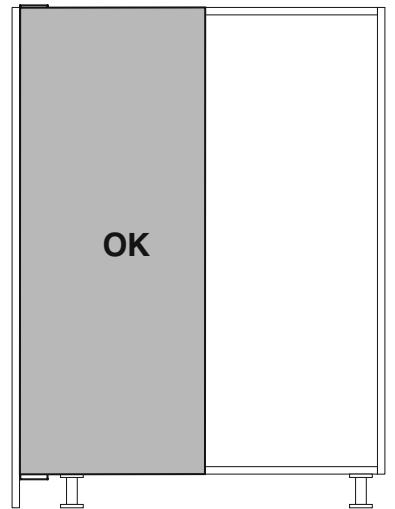
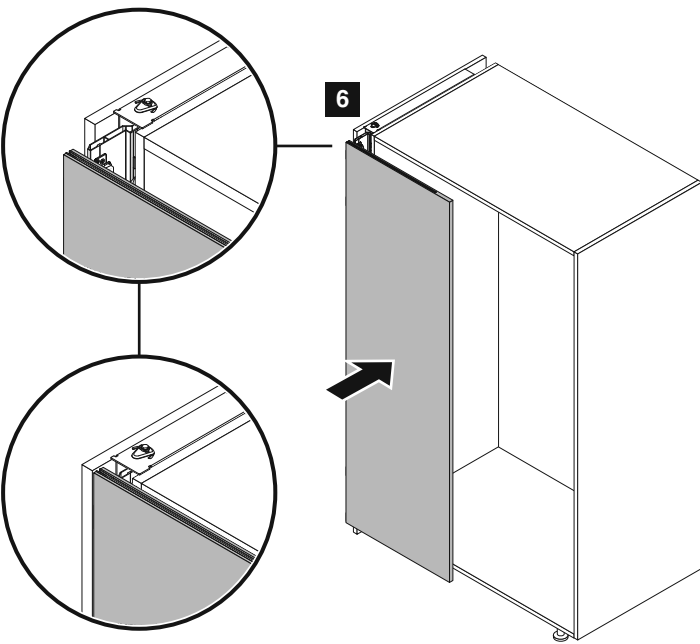
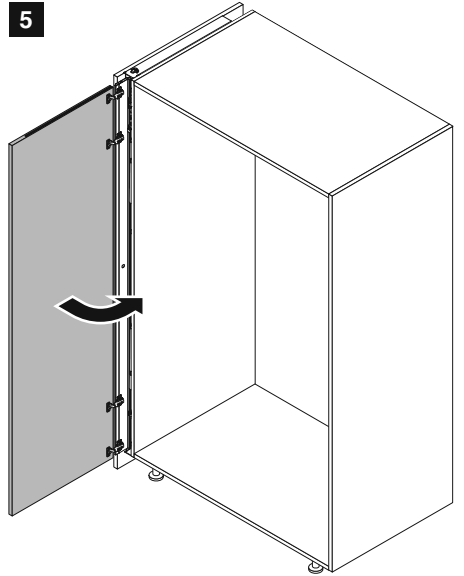

optional

**La pinna deve scorrere nella sede del profilo guida.**

The fin must slide in the seat of the guide profile.

L'ailette doit coulisser dans la gorge du profil de guidage.

Der Stift muss in den Sitz des Führungsprofils gleiten.

La aleta debe deslizar en la ranura del perfil guía.

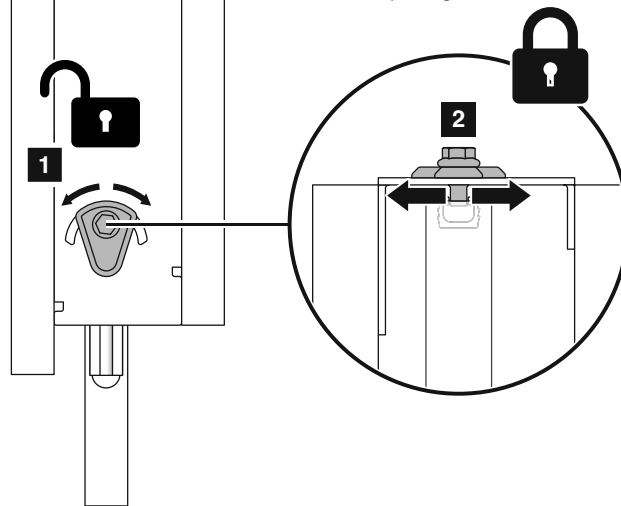

**Bloccaggio dello stop finecorsa magnetico anteriore.**

Lock of magnetic front end-stop.

Blocage du fin de course magnétique.

Befestigung des oberen Magnetanschlags.

Bloqueo del final de carrera magnético delantero.

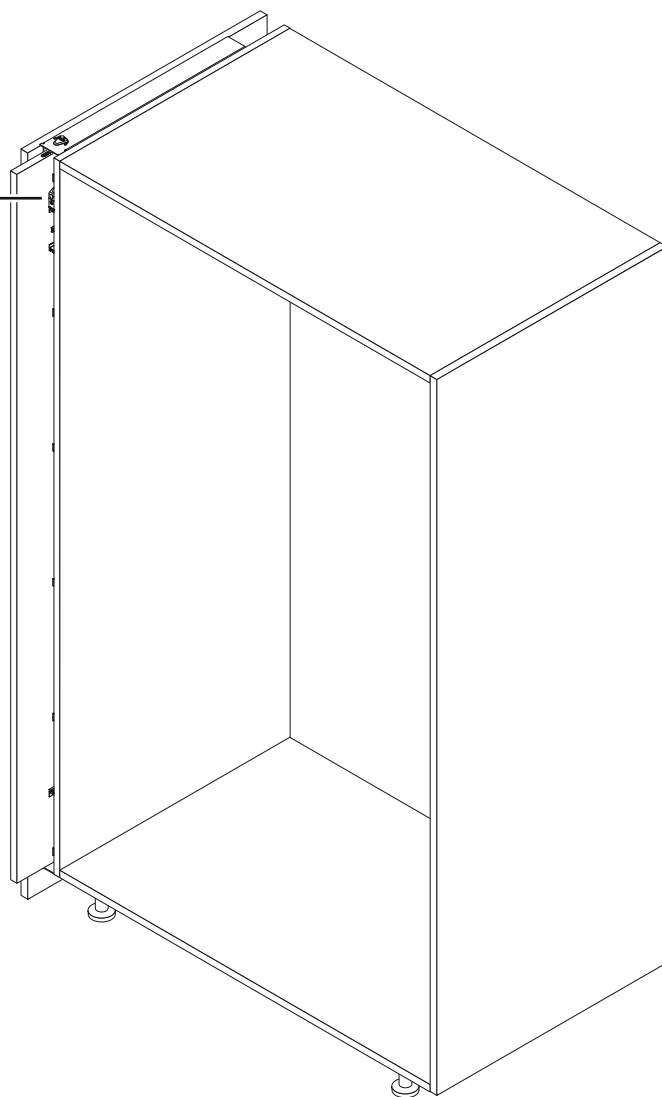
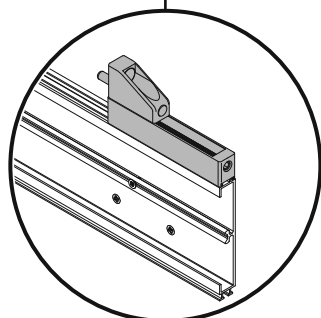
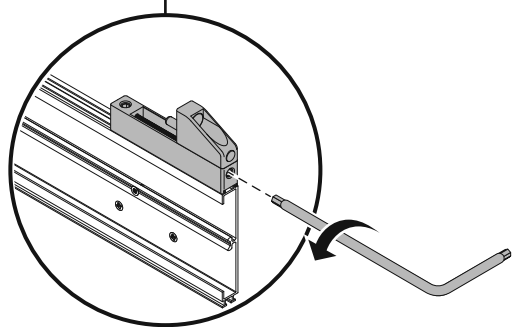
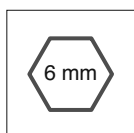
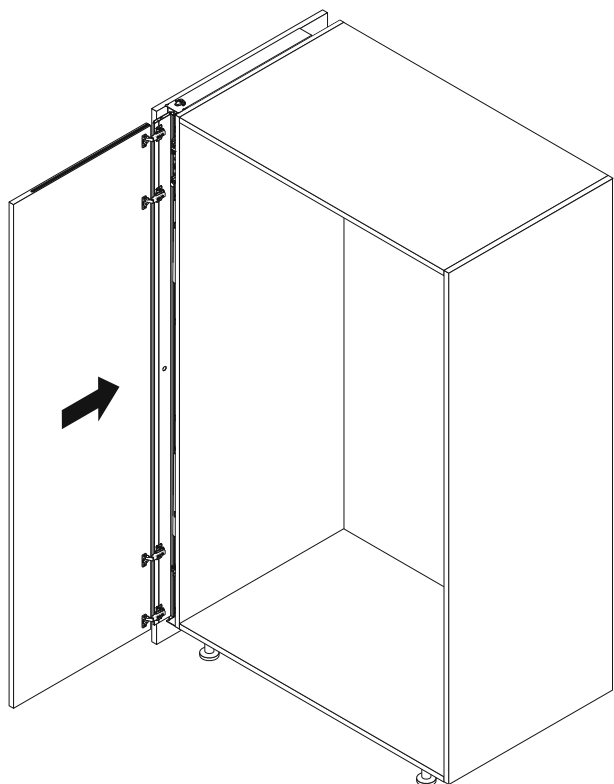

**Montaggio del profilo cover frontale.**

Mounting of the plastic front cover profile.

Montage du profil de finition.

Montage der Frontdichtung.

Montaje del perfil de cobertura frontal.

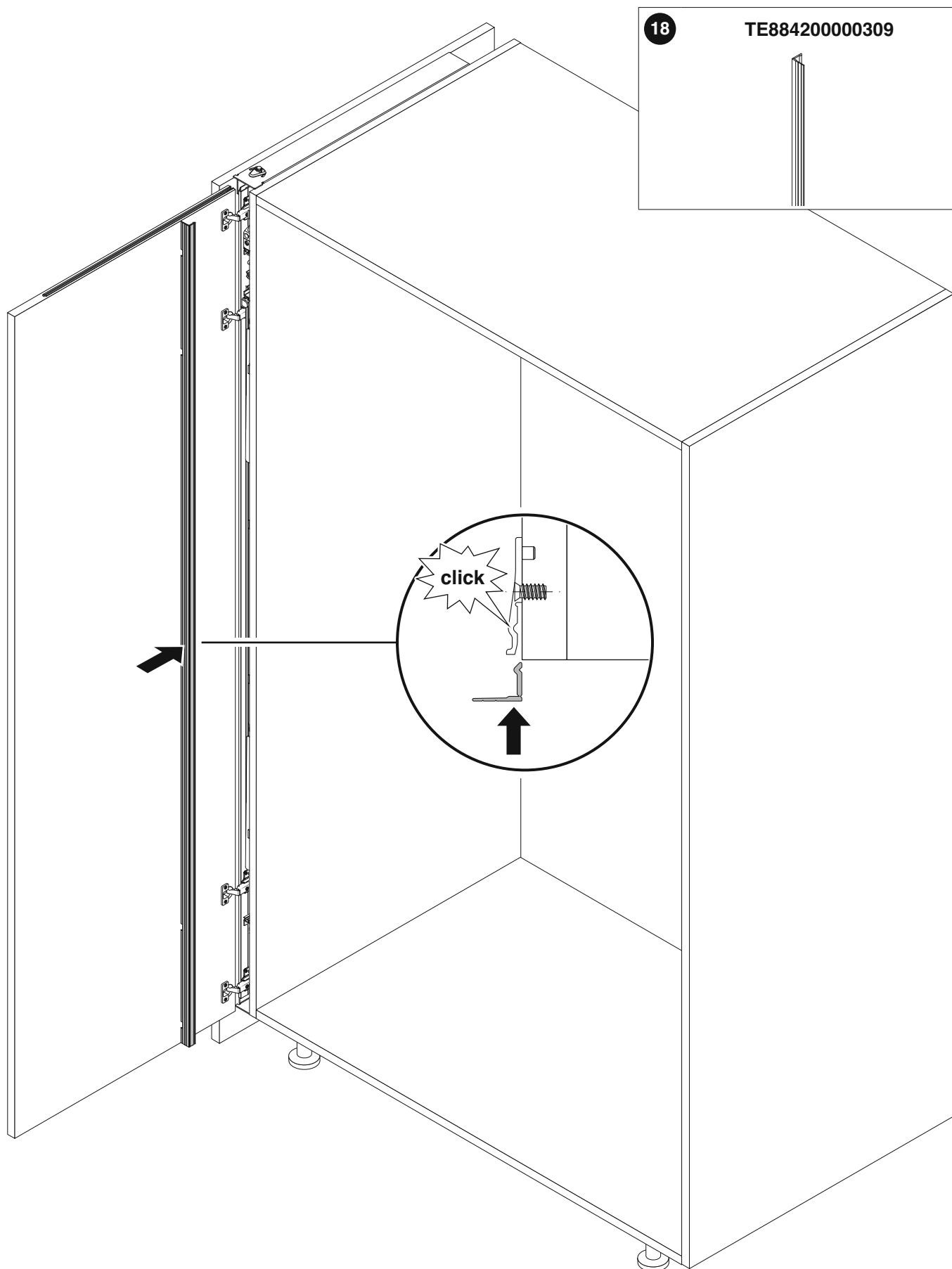







**Cinetto F.lli S.r.l.**

Via Rossi, 5/A

35030 Rubano (PD) Italy

Tel. +39 049 8977211

Fax +39 049 635822

[www.cinetto.it](http://www.cinetto.it)

[info@cinetto.it](mailto:info@cinetto.it)

